

**SIEMENS**

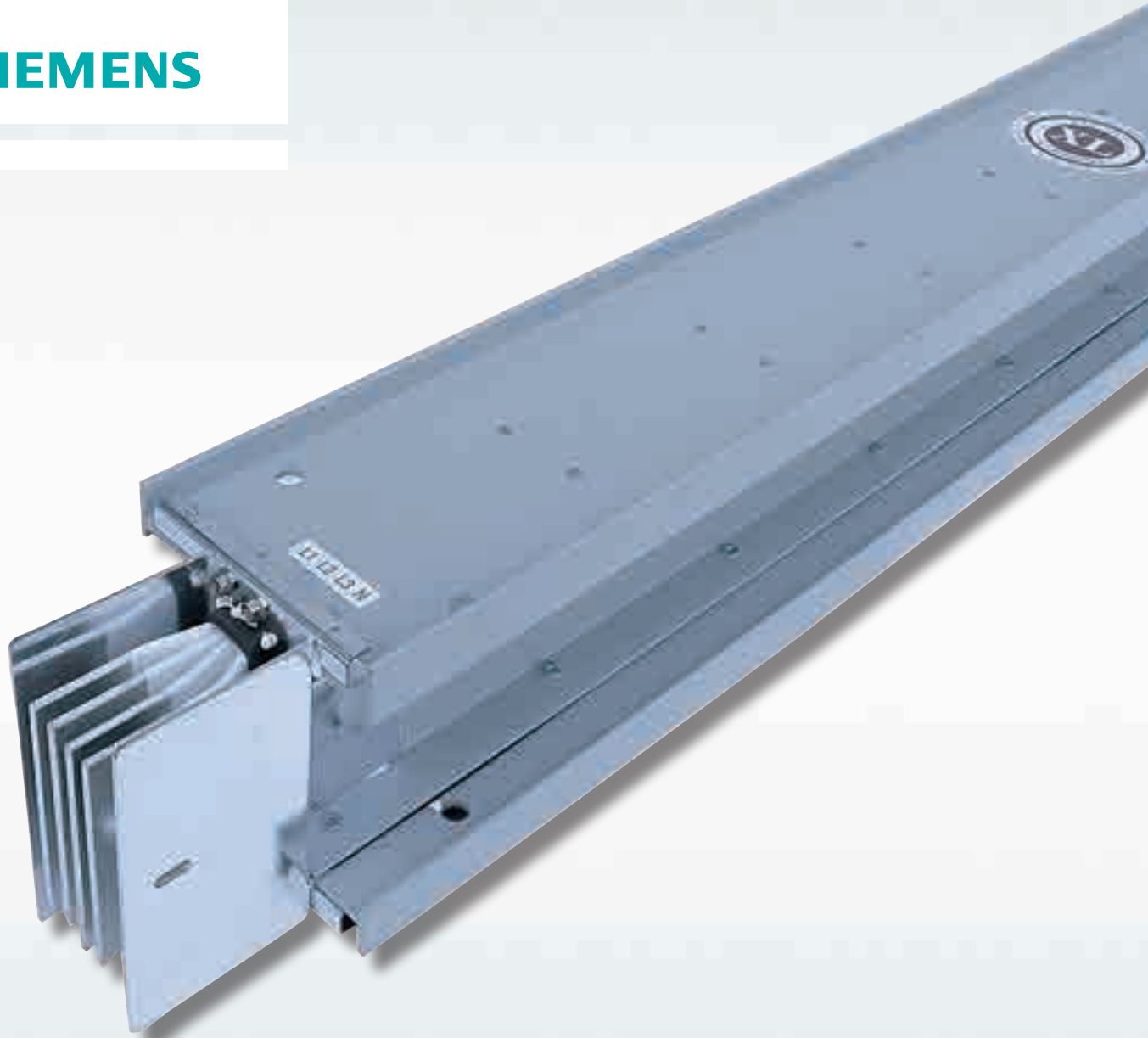

# SIVACON 8PS 母线槽系统

## XL-II 密集型母线槽系统

产品样本 • 12.2012

[www.siemens.com.cn](http://www.siemens.com.cn)

Answers for infrastructure and cities.

# XL-II 密集型母线槽系统

产品样本 • 12.2012



1

母线槽系统应用概述 ..... 3

2

## XL-II 密集型母线槽系统

系统描述 ..... 8

系统部件 ..... 9

加工设备 ..... 11

技术数据 ..... 12

产品编号 ..... 14

系统配置 ..... 16

3

## 功能单元

直线段单元 ..... 19

换向单元 ..... 21

与低压柜连接 ..... 23

与变压器连接 ..... 24

电缆进线单元 ..... 25

插接箱单元 ..... 26

连接器单元 ..... 28

系统附件 ..... 30

4

物理数据 ..... 31

5

## 其他

计算及选型 ..... 34

设计实例 ..... 36

母线槽系统的安装 ..... 40

本公司保留对简介所设计内容的修改权和最终解释权，如有改动，恕不另行通知。

This company reserves the right to revise and to explain finally for this catalog. Subject to change without prior notice. (2011)

# 母线槽系统应用概述

## System overview

### 概述

电力供电系统的设计，不仅要符合行业标准和设计规范，而且还要考虑到经济、安全、更能满足技术要求。对于电气设备的选择应以整个系统是否达到最佳配置为依据，而不受限于各个设备所具有的特性，比如说对于配电柜和变压器的选择，就应该考虑到设备之间的配套，将其作为一个整体，而不是单个进行选择。

元器件性能稳定，具有较强的适应能力，不仅适用于额定的工作环境，而且在相对恶劣的环境中也能使用。作为一套全新的电力输电系统应充分考虑到以下几点：

- 建筑物的类型、用途和形式（例如：高层建筑、平房和工业厂房等）。
- 变压器和配电柜的位置。
- 建筑管理部门的规定和指导方针。
- 供电部门的指导方针。

一般情况下，都会尽可能多的作出好几种设计方案，通过对技术和商务的综合考虑，选择最适合用户需求的、最经济节省的方案供用户最终确认。在作预算方案的时候，会优先考虑以下几点：

- 设计简单清晰
- 使用寿命长
- 实用性强
- 防火性能
- 建筑物更改时，设备能经过重新组装后再次使用

以上问题在工程项目中会经常碰到，母线槽系统由于其自身的特点能充分满足上述要求，所以在实际应用中，母线槽系统已经逐步替代了电缆，而成为工程人员心目中的首选输电产品。

### Overview

Creating a design concept for a power supply system, not only involves observing applicable standards and regulations, but also examining and clarifying economic and technical requirements. For electrical equipment selection should be based on whether the entire system can achieve the best configuration, but not limited to the integral features of equipments. For example, in choosing of connection between cabinets and transformers for the distribution, it should take into account the connections between devices as a whole rather than individual choice.

Components should not only be appropriate for rated operation, but should also be suitably dimensioned to withstand faults situations. A power distribution concept should also take the following points into consideration.

- Building type, use and form (for example, high-rise building, flat buildings and number of floors).
- Load centers and possible supply paths and location for transformers and main distribution boards
- Regulations and guidelines of building authorities
- Power supply company guidelines.

There will always be more than one possible solution which will have to be assessed in terms of its technical and economic advantages and disadvantages. In making this assessment, the following requirements should be a priority.

- Simple and transparent design
- Long service life
- High availability
- Low fire load
- Flexible adaptation to building modifications.

These requirements are generally easy to meet with appropriate busbar trunking systems. For this reason, engineers increasingly favor busbar trunking systems over cable installations for power transmission and distribution applications.

# 西门子低压母线系统是替代 电缆配电的经济、理想型方案

As a substitute for the cable distribution system, Siemens low-voltage busbar is the economic, ideal solution!

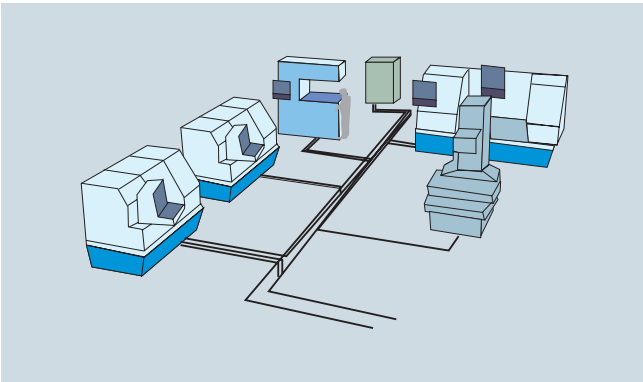

安装电缆时，新负载线路只能按照传统方法连接分支配电屏，费用高且安装复杂。

When install cables, the new load lines only in accordance with traditional connection methods to connect branch distribution board, costly and complicated to install

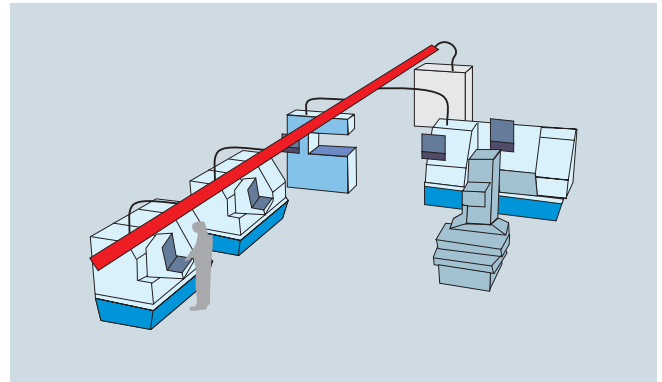

母线槽的插接单元接近负载设备，现场布局更清晰、灵活，经济实用。

The tap-off units of busbar system are close to the loading equipments, enjoying clearer site layout, flexible, economical and practical features.



电缆布线复杂，火灾荷载高  
Cable layout is complex, high fire load



母线设计简单清晰，火灾荷载低  
Busbar planning is easy, low fire load

# 西门子低压母线系统

## Siemens low voltage trunking system

母线槽系统主要作为变压器与配电柜之间的输电设备以及配电柜与负载之间的配电设备而被广泛使用，与电缆相比，母线槽系统不但安全，而且寿命长、性能可靠、使用方便。

西门子低压母线槽产品主要有以下几种类型：

As the power distribution equipment between transformer and switchgear, between switchgear and loading equipments, busbar trunking system is widely applied. Such system is more safe, long life-span, reliable and convenient to operate over cable installation.

Siemens Busbar Trunking Systems mainly offers the busbar trunking systems as the following types:

XL-II系统	额定电流400A~6300A
LR系统	额定电流630A~6300A
LD系统	额定电流1000A~5000A
BD1系统	额定电流140A~700A

西门子母线槽系统电流覆盖面广，产品种类齐全，能满足不同用户和工程项目的需求。所有母线槽系统均执行国际先进标准，并通过了国内外权威机构的各项检测与认证，如德国波恩实验室认证、英国ASTA、CCC认证等，这样就为产品的性能提供了保证。

Siemens busbar trunking system cover wide current range, varied products can meet the needs of different users and the demand for projects. All the busbar systems are type-tested low-voltage assembly (TTA) in accordance with international advanced standard IEC/EN, passed a series of international and domestic tests and certificates, such as Germany Bonn Electric Laboratory Test, ASTA from UK, CCC, etc. which guarantee our products performance.

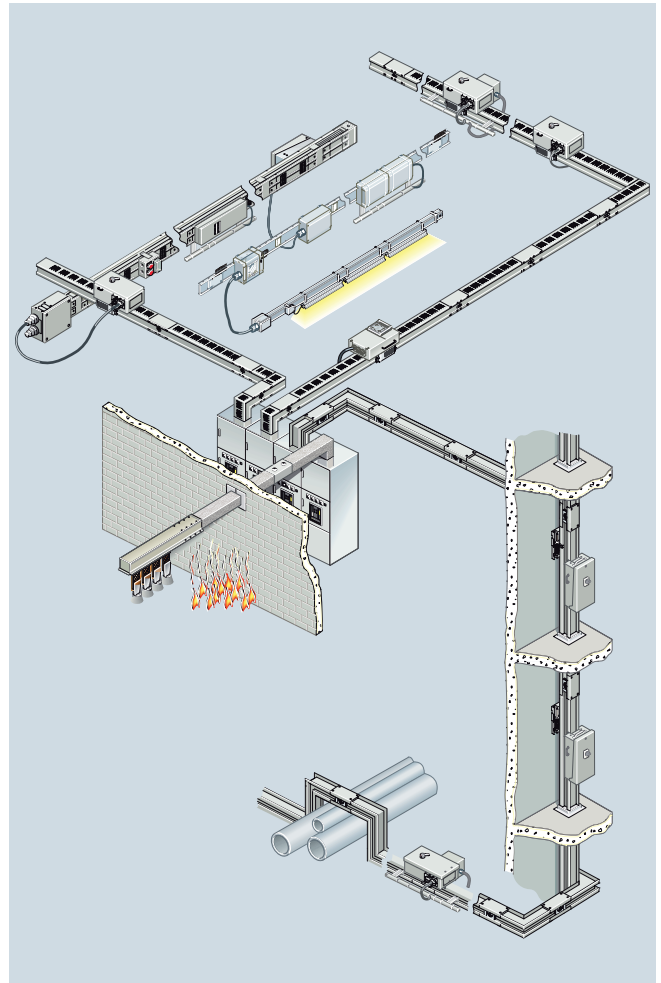

# 产品

## PRODUCTS

### 适应性强的LR全封闭环氧树脂浇注母线系统

#### The Adaptive LR Super Compact Resina Casting Busbar System

LR系统设计电流从630A-6300A，外壳采用环氧树脂整体浇注，是由西门子和世界最大的化学公司CIBA经过多年时间共同研制开发，该独特配方具有优越的电气绝缘性能及良好的散热性能，防护等级高达IP68，具有防水、防火、防爆、防腐等优势，是低压配电领域的新一代输配电系统。适用于各种恶劣环境，被广泛应用于造船、机械电子、石油化工、钢铁冶金和大型建筑等各种场所。

The LR system rated current ranges from 630A-6300A; It adopts resina casted enclosure, Which is cooperated out by Siemens and the biggest Chemical Co. worldwide "CIBA" for more than 20 years. The special mixture material enjoys excellent electric insulation performance and perfect heat dissipation capacity. The protection degree is IP68, anti-erosion, water-proof, fire-proof and EX-protected. Specifically provides heavy current power distribution for aggressive circumstances such as shipyard, power plant, chemical industry, out door power distribution, etc.



图1：LR浇注母线系统拥有IP68的超高防护等级，被广泛应用于造船、冶金、石油化工等各行业。

Figure 1: LR Super Compact Resina casting busbar system holds IP68 super high protection degree, widely applied for shipyard, steel and chemical industry.

### 国际领先水准的LDA风力发电母线系统

#### The advanced LDA Wind Power Busbar System

LDA母线槽系统是西门子为了满足市场需求，针对风力发电行业专门研制开发的母线槽输配电系统，设计电流为900A-3400A，其特殊的结构能有效解决塔筒摆动带来的影响，对恶劣的环境和温度变化有较强的适应性。该系列产品的成功研发弥补了国内风电行业母线空缺，引领母线技术发展的新潮流。

In order to meet the market demand, Siemens specially developed LDA busbar system for wind power industry, rated current ranges from 900A-3400A. The advanced design adopts special structure which can remove the influence of shaky cylinder and resistant to aggressive atmosphere and temperature changing.



图2：专为风力发电行业而设计的LDA母线系统适用于塔筒内发电机定子和转子的输出回路，设计先进，环保，安全可靠。

Figure 2: LDA wind power busbar system is applied for the rotator and stator transplant loop of generator in cylinder, enjoying advanced planning, Environmental protection, safety and reliability.

## 性能可靠的LD空气型附加绝缘型母线槽系统 The Reliable LD Additional Air-Insulated Busbar System

LD系列母线作为大电流的输配电系统，主要用于电力变压器和低压配电屏以及重型负载之间的连接。它具有安装迅速、使用方便、安全可靠等特点，适用于汽车制造、电机制造、工业用电炉以及高层建筑的供电等。同时LD母线槽系统在穿墙使用时采用专用防火栅，在发生火灾危险时，能阻止烟、火、热通过母线槽单元蔓延到临近房间或楼层，甚至能防止灭火时水的渗透。

As the heavy current power distribution and transportation busbar, LD system rated from 1000A to 5000A, mainly used for connecting low-voltage switchgear and transformer or other heavy-load equipments. It shares fast installation, convenient and safe performance, etc. which serves for automobile manufacturing, generator manufacturing, industrial workshop and power supply for high-rise, etc. Meanwhile, LD system uses special fire barrier through the wall, preventing the fire and smoke spreading into the near room or floor through the busbar, even can hinder the fire-fighting water's infiltration.



图3：LD母线槽系统作为理想的大电流输配电设备被广泛应用在工矿企业，例如图中应用在上海大众汽车装配流水线。  
Figure 3: LD system is the ideal busbar for heavy current power distribution and transportation. It is mainly applied in industrial and mineral workshop, etc. e.g. common in applying for auto industry, Shanghai Volkswagen.

## 技术新颖的BD1空气绝缘型母线槽系统 Brand-New BD1 air-insulated busbar system

BD1母线槽系统电流从140A~700A，是一种新型的封闭式配电系统，广泛应用于中小型负载的配电，具体场所有工厂、高层建筑、实验室、展览中心等，该系统机械强度高、绝缘性能强，且具有操作简便、配置齐全、重量轻等优势特征。

BD1 busbar system rated from 140A-700A, is a new type of enclosed power distribution system, which can be applied for workshop, high-rise, laboratory and exhibition center, etc. It enjoys advantages such as high mechanical strength, excellent insulation performance, light weight, easy operation and complete configuration, etc.



图4：BD1母线槽系统安装简便，适用于工厂、商业建筑、实验室和展览中心等。  
Figure 4: BD1 system enjoys easy installation, is the ideal busbar for workshop, commercial buildings, labs and exhibition hall.

# XL-II密集型母线槽系统

## 系统描述 System overview

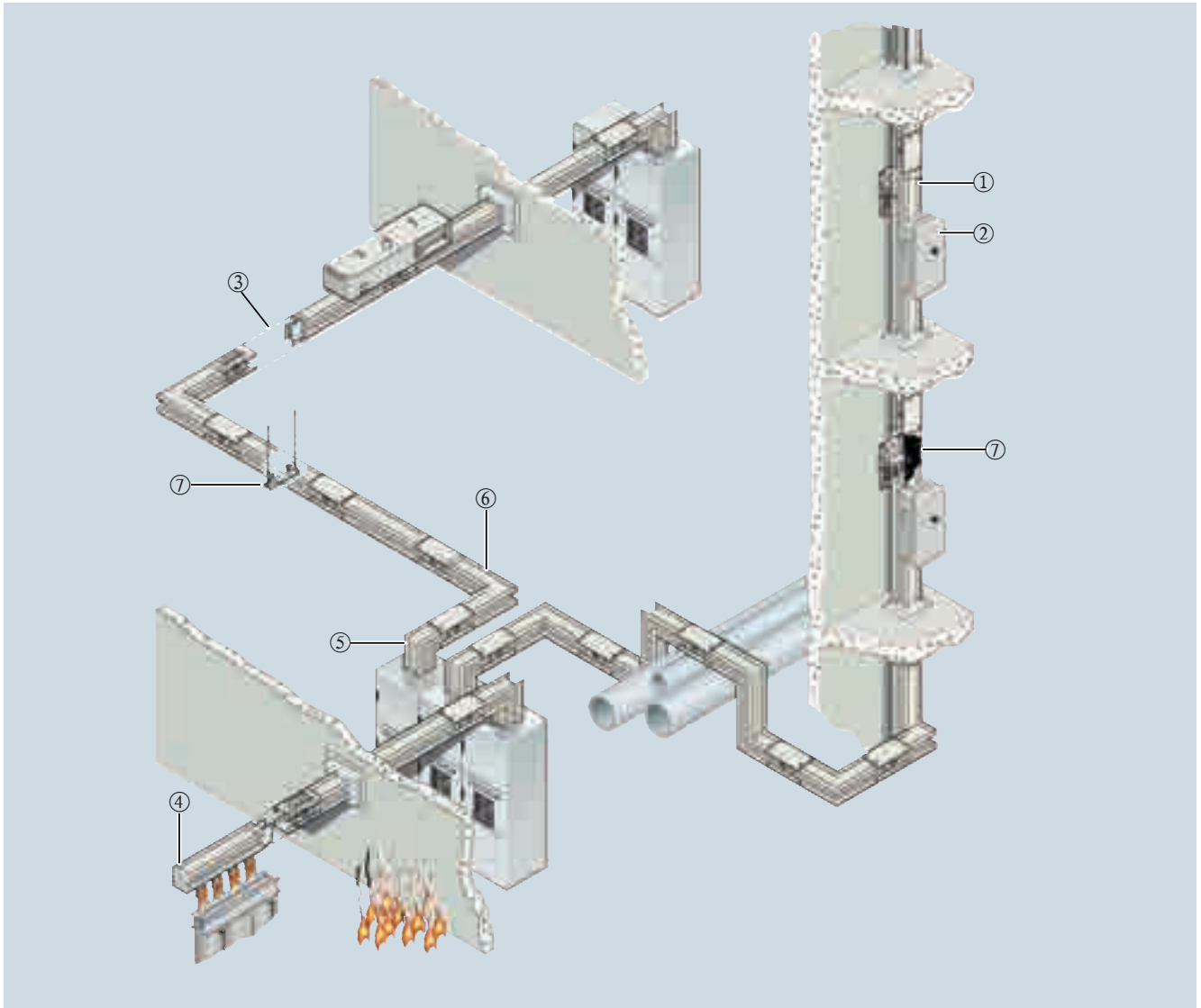

- ① 直线段单元 Straight trunking units (with or without tap-off points)
- ② 插接箱单元 Tap-off units, can be connected whilst live
- ③ 连接器单元 Joint pack units
- ④ 变压器连接 AS单元 Feeder units
- ⑤ 低压柜联络单元 Connection to Siemens power distribution boards
- ⑥ 换向单元 Junction units
- ⑦ 安装附件 Additional equipment for wall/ceiling mounting

XL-II密集型母线槽是西门子综合中国市场的特点而研制的更贴近用户需求的新型密集型母线系统。该系统在原有基础上进行升级，自动化生产程度更高，能满足不同用户群的配电需求。

Combining successful sales and manufacturing experience, Siemens makes XL-II compact system much closer to customer. The system is upgraded on the original type, enjoying higher automation degree to meet different customers' requirements. And it will lead the new technical developing direction of busbar for sure.

# XL-II密集型母线槽系统

## 系统部件 System components

### 系统部件基本描述

XL-II母线槽系统既可应用在变压器与配电柜之间的连接，还可以为负载进行供电系统提供的防护等级最高可达IP65，能适应各种恶劣环境，插接箱输出电流最大可以达到1250A，为用户提供了可靠的负载环境，高的防护等级也为维护人员的安全提供了保证。

#### 1. 直线段单元

根据需要可以加装穿墙套单元，  
防护等级IP54，  
(最高可以达到IP65)

##### 馈电式和插接式

标准长度

XLA-II: 4m/3m/2m/1m

XLC-II: 3m/2m/1m

可选长度

XLA-II: 0.44 - 3.99 m

XLC-II: 0.5 - 2.99 m

可垂直安装也可水平安装

##### 插接母线

单面设插口

双面设插口

插口提供的防护等级为IP54

能有效防止错相安装

##### 防火母线

通过JB/T10327-2002规定

阻燃性能试验

#### 2. 插接单元

采用断路器保护或熔断器保护

钢制外壳

具有良好的接地

防护等级高达IP54

表面标准颜色：RAL7032 RAL7035

安装方便

机械联锁装置和自动定位装置

能有效防止错相安装

插脚镀银处理

### System components overview

XL-II system is the excellent choice to connect transformer and switchgear, and also to supply power for loading equipments. The highest protection degree of IP68 can meet different aggressive environment. The largest tapping current 1250A provides reliable power loading condition and higher personnel safety.

#### 1. Straight trunking units

If needed wall-through cover unit is available.

Protection degree: IP54

(The highest is IP65)

##### With or without tap-off points

Standard length

XLA-II: 4m, 3m, 2m, 1m

XLC-II: 3m, 2m, 1m

Optional length:

XLA-II: 0.44 - 3.99m

XLC-II: 0.5 - 2.99m

Optional for vertical and horizontal installation

##### With tap-off points straight trunking unit

Single side with tap-off points

Double sides with tap-off points

Tap-off point protection degree is IP54

Anti-wrong installation device

##### Anti-fire straight trunking unit

Passed the JB/T10327-2002 regulation

Anti-fire capability test

#### 2. Tap-off units

Adopts breaker or fuse switch as protection

Steel enclosure

Excellent earth device

Protection degree: IP54

Standard color: RAL7032 RAL7035

Easy installation

Mechanical inter-lock device and auto-positioning device

Plug feet silver plated

# XL-II密集型母线槽系统

## 系统部件 System components

### 3. 进线单元

#### 变压器进线单元

配置有专门的软连接装置

最大额定电流达到6300A

#### 低压柜进线单元

配置有专门的硬连接(连接铜排)装置

最大额定电流达到6300A

或采用电缆进线单元

### 4. 与西门子低压柜进行连接

从顶端进线

从底部进线

### 5. 换向单元

方便的更改一段母线的走向

角度为70~175度

L型单元

T型单元

Z型单元

### 6. 附件

终端封

连接器

安装件

连接工具

### 3. Feeder Units

#### Transformer feeder units

Special flexible connection

Rated current up to 6300A

#### Distribution board feeder units

Special copper bar connection

Rated current up to 6300A

Or cable feeder unit

### 4. Connection to Siemens power distribution systems

Above

Below

### 5. Junction units

Easily change the busbar system direction

70° ~ 175°

L unit

T unit

Z unit

### 6. Accessories

End cap

Joint pack

Fixing bracket

Tools for connection

# XL-II密集型母线槽系统

加工设备



西门子拥有全球第一台最先进的母线槽自动装配流水线。

## 母线装配

与传统密集型产品不同，XL-II 密集型母线系统引进英国亨罗布自冲铆接技术，外壳整体结构采用铆钉铆接，自动化生产程度高。利用液压传动可获得较大、均匀的压力，使得母线槽整体强度得到大幅度提升，并且具备良好的密封效果和防渗功能，防护等级高，电气连续性优，外形整洁美观。

The world's leading British Henrob self-piercing riveting technology and international leading XL-II busbar automatic assembly lines.

## Busbar assembly

Different with traditional compact products, XL-II adopts the British Henrob self-piercing riveting technology, the overall structure of enclosure are riveted together automatically, ensuring high degree of automation. The use of hydraulic pressure makes the overall strength of busbar been substantially upgraded, and have a good sealing effect and anti-seepage feature, high-grade protection, excellent electrical continuity, clean and beautiful appearance.



# XL-II密集型母线槽系统

## 技术数据

### 系统通用参数

环境温度	
Min./max./24 小时平均温度	-5/+40/35°C
防护等级	IP54、IP65
连接器力矩	70Nm
表面处理	喷塑
外壳材料	铝镁合金
外壳颜色	国际标准灰 (RAL7032、RAL7035), 具体颜色也可用户确定
额定绝缘电压 $U_i$	1000VAC
额定工作电压 $U_e$	660VAC
额定频率 $f$	50Hz
额定电流 $I_e$	1)
额定短时耐受电流 $I_{cw}$	1)
额定峰值耐受电流 $I_{pk}$	1)
导体截面	1)
L1, L2, L3	1)
N	1)
PE	1)
单独一根导体作PE	1)
导体材料	CU、AL
每相铜排数	1)
最大安装间距	
水平	
Horizontal, flat	2m
外形尺寸	1)
重量	1)

注：1) 选择不同的电流等级，相对应不同的数据。

2) 详细的数据可以参照下一节技术参数表部分。

Note: 1) Different current range gets its corresponding technical data.

2) Detailed data please refer the technical parameter list in the next part.

XLC-II参数一览表

电流	短时耐受 电流 (I <sub>CW</sub> ) KA	峰值耐受 电流 (I <sub>PK</sub> ) KA	电阻 / 米 (MΩ)	电抗 / 米 (MΩ)	阻抗 / 米 (MΩ)	每米压降 (V)	外形尺寸		每米重量 Kg / 米	
							宽度 (W)	高度 (H)	4 线制	5 线制
400	30	63	0.110	0.039	0.116	0.08	145	114	11.8	12.6
630			0.094	0.035	0.101	0.11	145	114	12.9	13.8
800			0.073	0.031	0.079	0.11	145	114	15.0	16.2
1000	50	105	0.060	0.028	0.066	0.11	145	119	17.2	18.7
1250			0.047	0.024	0.053	0.11	145	134	20.7	22.5
1600	65	143	0.033	0.020	0.039	0.11	145	164	27.6	30.2
2000			0.024	0.017	0.030	0.10	145	199	35.6	39.2
2500			0.018	0.014	0.023	0.10	145	244	45.9	50.7
3150	100	220	0.015	0.012	0.019	0.10	145	373	60.2	66.1
4000			0.011	0.009	0.014	0.10	145	443	76.3	84.0
5000			0.009	0.006	0.011	0.09	145	533	97.0	107.1
6300	120	264	0.007	0.004	0.008	0.08	145	613	124.5	127.6

XLA-II参数一览表

电流	短时耐受 电流 (I <sub>CW</sub> ) KA	峰值耐受 电流 (I <sub>PK</sub> ) KA	电阻 / 米 (MΩ)	电抗 / 米 (MΩ)	阻抗 / 米 (MΩ)	每米压降 (V)	外形尺寸		每米重量 Kg / 米	
							宽度 (W)	高度 (H)	4 线制	5 线制
400	30	63	0.130	0.029	0.133	0.09	145	114	8.6	9.0
630			0.118	0.028	0.121	0.13	145	119	9.0	9.5
800			0.093	0.024	0.096	0.13	145	134	10.2	10.8
1000	50	105	0.065	0.020	0.068	0.12	145	164	12.7	13.5
1250			0.048	0.017	0.051	0.11	145	199	15.5	15.5
1600	65	143	0.036	0.014	0.039	0.11	145	244	19.2	20.6
2000			0.029	0.012	0.032	0.11	145	373	27.5	29.2
2500			0.022	0.009	0.024	0.10	145	443	33.1	35.5
3150	100	220	0.017	0.006	0.018	0.10	145	533	40.4	43.5
4000			0.013	0.004	0.013	0.09	145	613	46.9	54.2

# XL-II密集型母线槽系统

## 产品编号

### 产品编号

XL-II 母线槽系统对一些基本的部件进行了编号，包括额定电流、导体配置、导体截面和导体材料等，下面的图示就反映了这一产品代码系统，用户可以根据此系统进行产品的订货选择。

### Product code

XL-II busbar system has a set of codes for basic units, including rated current, conductor configuration, conductor cross-section and conductor material. The customer can choose according to system codes below while ordering.

#### 选型案例：

项目额定电流 2500A，应用铜母线系统，5 线制，外壳作 PE。

系统代码为：XLC-II 0851

#### Example:

Rated current is 2500A, copper conductor, 5W, enclosure as PE

Then the system code is XLC-II, 0851

- 1) 外壳作PE
- 2) 外壳与PEN相连
- 3) 单独PE导体

- 1) Enclosure as PE
- 2) Enclosure connects with PEN bar
- 3) An independent bar as PE

		Ordering type	
防火型 Fire protection	XL - II		S120-X
常用型 Basic type	XL - II		
Conductor material			
Al	A		
Cu	C		
Rated current Ie [A]			
Al	Cu		
400	400	01	
630	630	02	
800	800	03	
1000	1000	04	
1250	1250	05	
1600	1600	06	
2000	2000	07	
2500	2500	08	
3150	3150	09	
4000	4000	10	
	5000	11	
	6300	12	
Configuration of the conductors			
L 1+L 2+ L 3+PE 1)		30	
L 1+L 2+ L 3+ PEN/PEN 2)		41	
L 1+L 2+ L 3+N+PE 1)		51	
L 1+L 2+ L 3+N+PE 3)		53	
Fire protection			
Positioning (X*)			

## 插接箱编号

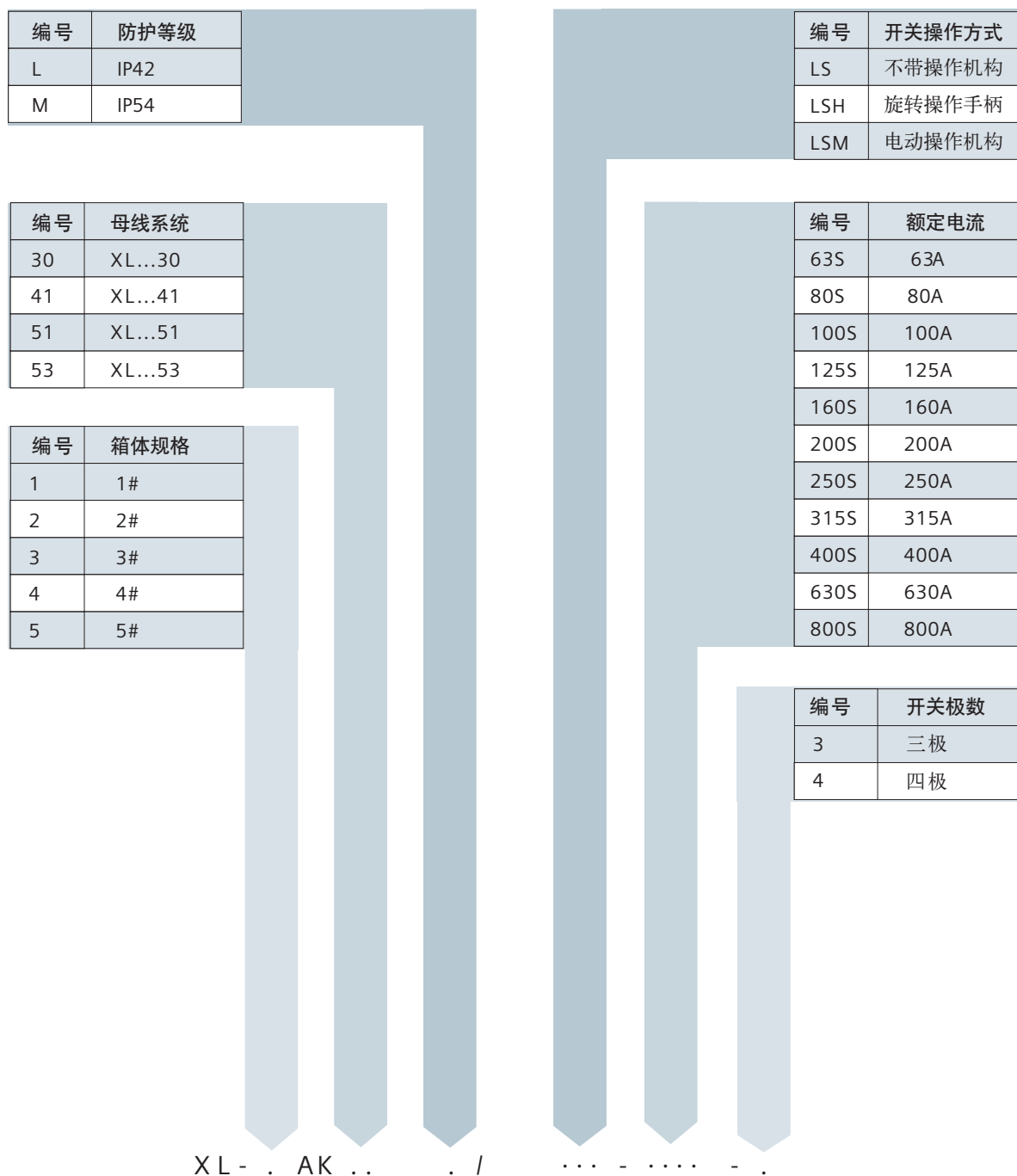

举例：XL-2AK51M/LSH-125S-3表示箱体规格为2#、母线系统为51、防护等级为IP54的插接箱，采用断路器保护并带有旋转操作手柄，断路器为3极、额定电流为125A。

Example: XL-2AK51M/LSH-125S-3 represents tap-off box specification is 2#, busbar system is 51, IP54, breaker protection and Rotary operating handle, breaker is 3 poles, and rated current is 125A.

# XL-II密集型母线槽系统

## 系统配置

### 外壳

XL-II系列母线槽采用优质铝镁合金型材作为外壳，为无磁性环保材料，重量轻，散热快，母线槽运行时无磁滞涡流损耗，并且其足够大的截面能取代PE线作为100%整体式接地，表面静电粉末喷涂，通过1200h的耐盐雾实验，可长期应用于空气湿度大、盐分高、污染等级高的环境。

### Enclosure

XL-II system adopts excellent alloy as enclosure material, enjoys non-magnetism, environment protection, light weight and fast heat dissipation capability. No-eddy current loss when system on loading. The large enough Cross-section can replace the PE as 100% integral earth. The surface is static painted and passed the 1200h salt withstand test, which can meet the high air humidity, salt separating, high pollution etc. Environment.

### 导体

XL-II母线槽系统表面镀锡或者镀银，全长整体包裹高性能绝缘材料聚酯薄膜；

XLC-II为铜导体系统，XLA-II为铝导体系统。铝导体表面镀锡前做镀镍或镀铜处理。



### Conductor

The conductors of the XL-II busbar system are normally tinned or silver plated, totally covered with highly insulation material.

XLC-II is copper system; XLA-II is aluminum system. Aluminum conductor should be nickel-plated and copper-plated before tin-plated.

高性能绝缘材料

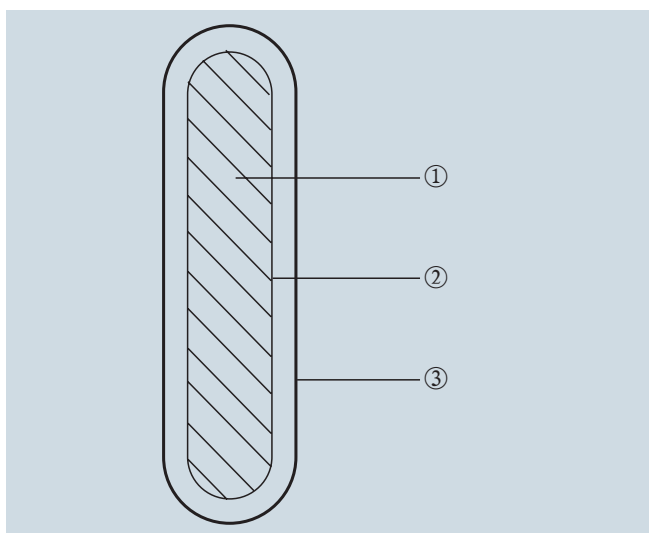

XL-II母线系统

- ① 导体，铜排(XLC-II)；铝排(XLA-II)
  - ② 镀层，镀锡层(XLC-II)；镀镍层，镀铜层，镀锡层(XLA-II)
  - ③ 高性能绝缘材料聚酯薄膜
- 
- ① Conductor, copper bar (XLC-II), aluminum bar(XLA-II)
  - ② Coating. Tin coating (XLC-II), nickel coating, copper coating, tin coating(XLA-II)
  - ③ Insulation Material

## 母线安装

XL-II母线系统的内部为典型的三明治结构，而且保持全长密集，这种特殊的结构决定了XL-II母线系统的承载电流不会受安装位置及安装方式的影响，我们将会根据现场情况设计一个合适的走向。

## PRODUCTS

The sandwich-type construction of the XL-II busbar system maintains a total length of compact structure, which means that its current loading capacity is not affected by the mounting position. We offer the optimum flexibility in planning busbar layout according to the site condition.

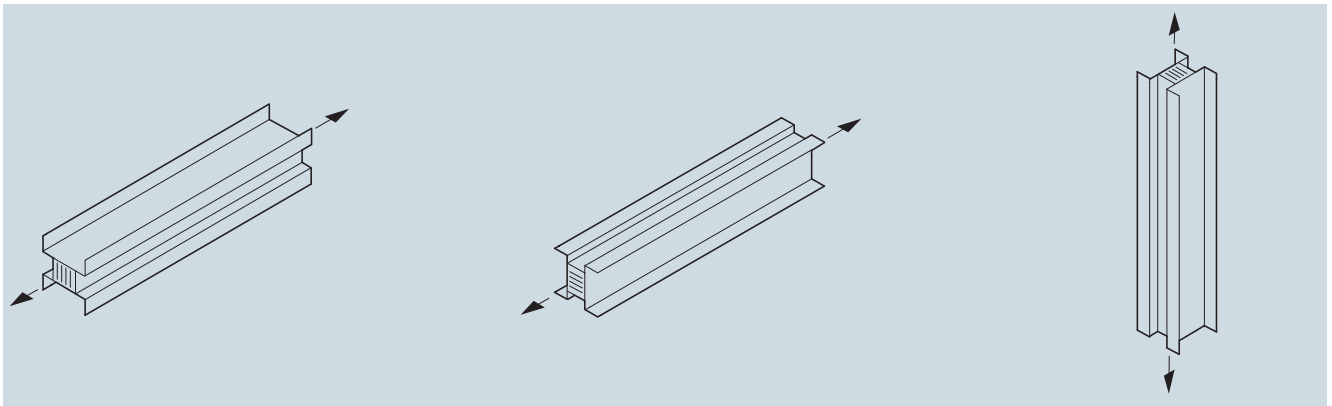

水平安装，立装  
Horizontal installation, edgewise

水平安装，侧装  
Horizontal installation, flat

垂直安装  
Vertical installation

## 外形尺寸

外形尺寸主要决定于母线槽系统的额定电流和导体材料，XL-II系统总共分12个电流等级，其中8个小电流等级系统采用单排，其余为双排。

## Dimensions

The dimensions depend on the rated current and conductor material. XL-II busbar system can be divided into 12 current ratings, among them, 8 ratings adopt single bar stucture and the rest are double bar stucture.

电流A	高H (mm)	
	XLC-II	XLA-II
400	114	114
630	114	119
800	114	134
1000	119	164
1250	134	199
1600	164	244
2000	199	373
2500	244	443
3150	373	533
4000	443	613
5000	533	
6300	613	

注：宽度均为145mm  
Width is always 145mm

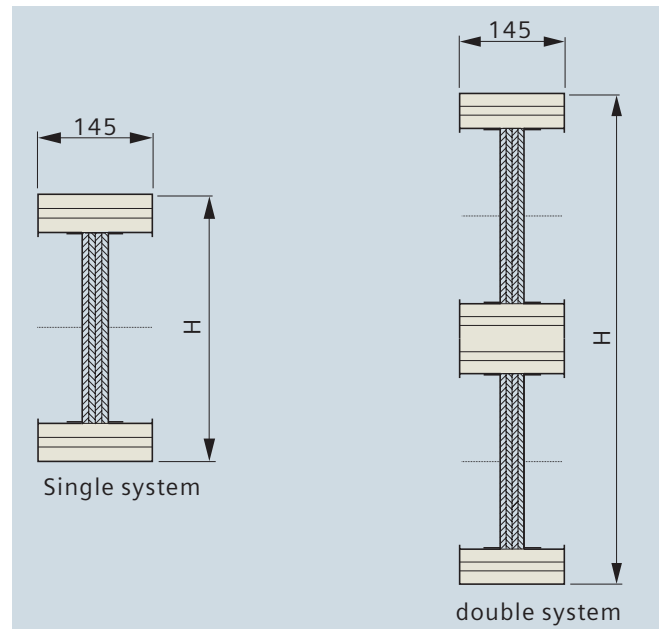

# XL-II密集型母线槽系统

## 系统配置

### 导体配置

IEC364标准规定配电设备的系统配置需根据整套系统配置进行选择，而且所选择的设备要充分保证整个系统的安全。

XL-II母线槽系统拥有多种导体配置系统，能适应不同工程对系统的要求。

### Conductor Configurations

The IEC standard regulates that the power distribution equipment system configuration should be based on the entire system configuration, and the choice of equipment should fully guarantee the security of the entire system.

XL-II busbar system offers many different conductor configurations to meet per actual site requirement.

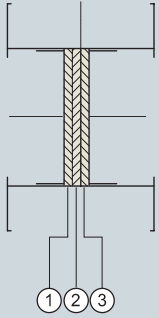
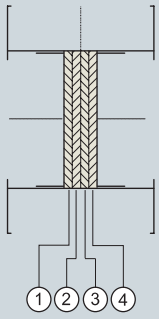
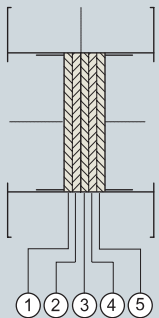
	系统 System	导体配置 Conductor configurations						外壳 Enclosure
		①	②	③	④	⑤	⑥	
	XL-II ... 30	L1	L2	L3	-	-	-	外壳作 PE Is the PE conductor
	XL-II ... 41	L1	L2	L3	PEN	-	-	外壳与 PEN 相连
	XL-II ... 51	L1	L2	L3	N	-	-	外壳作 PE Is the PE conductor
	XL-II ... 53	L1	L2	L3	N	PE	-	单独 PE 导体

外壳作PE：通过验证采用无磁性的铝镁合金外壳作为整体式接地导体，它的接地容量超过相线100%。当系统出现高容量的接地故障时，使系统直接与大地相通，它具备最短的接地途径。

Enclosure as PE: adopting excellent non-magnetism alloy enclosure as integral conductor. The earth capability is more than 100% phase conductor. When there is a high earthing fault, it connect busbar with the ground directly, which offers the shortest earth approach.

# 功能单元

## 直线段单元 Straight trunking units

### 直线段单元

XL-II密集绝缘型母线槽壳体结构为完全密封型，最高防护等级可达IP65，可在恶劣环境条件下使用。系统选择具有大于相线100%容量的整个外壳作接地系统，保证足够的安全性，为接地故障提供可靠的接地路径，为地线短路提供最短的路径。当发生高容量的接地故障时，可有效的接地和保护整个系统。馈电式母线槽可以垂直安装也可以水平安装。

### Straight trunking units

XL-II busbar system adopts totally enclosed structure with the max protection degree of IP65, making the system be applied in aggressive environment and allowed entire enclosure (100% more capacity than phase conductor) as earth system, which passed the ASTA approval. That guarantees system safety, shortest and reliable earth approach. When there is a high earthing fault, it can protect the entire system effectively. Straight runs without tap-off units are available with vertical and horizontal installation.

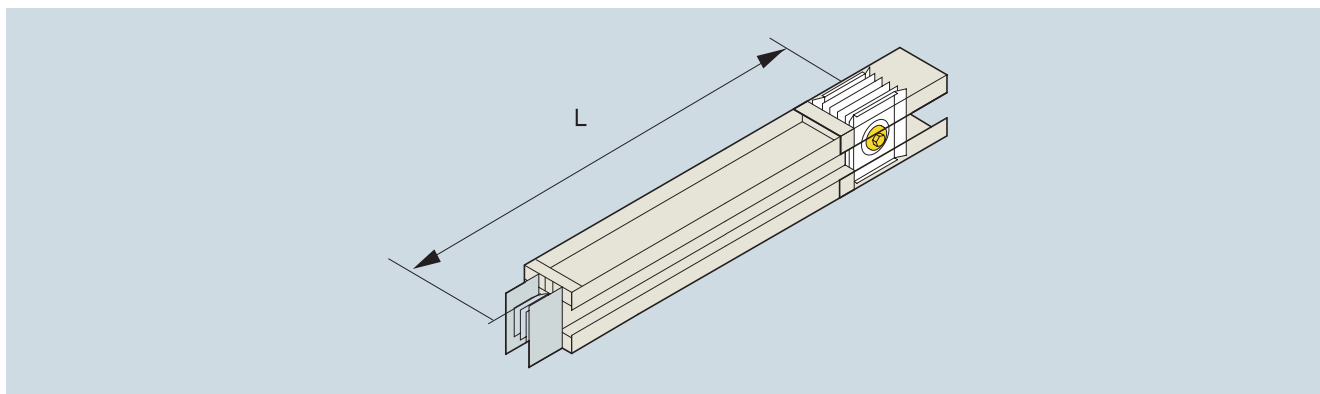

标准长度	
XLC-II	1m XLC-II ... -1W*
	2m XLC-II ... -2W*
	3m XLC-II ... -3W*
可选长度	
XLC-II	0.35m-0.99 XLC-II ... -1W*
	1.01m-1.99 XLC-II ... -2W*
	2.01m-2.99 XLC-II ... -3W*

标准长度	
XLA-II	1m XLA-II ... -1W*
	2m XLA-II ... -2W*
	3m XLA-II ... -3W*
	4m XLA-II ... -4W*
可选长度	
XLA-II	0.35m-0.99 XLA-II ... -1W*
	1.01m-1.99 XLA-II ... -2W*
	2.01m-2.99 XLA-II ... -3W*
	3.01m-3.99 XLA-II ... -4W*

# 功能单元

## 直线段单元 Straight trunking units

插接式母线槽系统可以垂直安装也可以水平安装，插口的设置比较灵活，双面都可以设插接口，插口之间的最小间距为575mm，3米长标准段最多可以配置10个插口，用户可以根据具体情况预留插接口以便在设备负载更换位置或增加时，母线槽单元依然可以适应负载的要求，为用户提供安全可靠及便利的用电环境。

Straight trunking with tap-off units are available with vertical and horizontal installation. The tap-off point can be planned flexibly with double sides at the min span of 575mm. The 3m length straight unit can be planned with max 10 tap-off units. The users can reserve tap-off points in case of changing and increasing load equipment later according to the site condition.

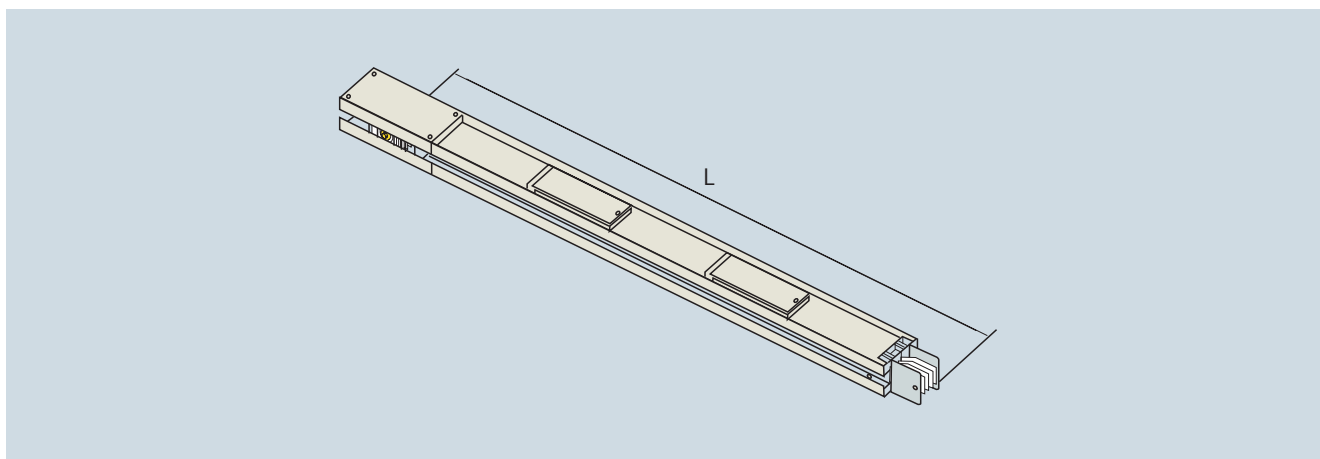

标准长度	
XLC-II	L = 1、2、3m
可选长度	
XLC-II	L = 0.7 ~ 2.99m

标准长度	
XLA-II	L = 1、2、3、4m
可选长度	
XLA-II	L = 0.7 ~ 3.99m

# 功能单元

## 换向单元 Junction units

### 换向单元

为了方便更改一段母线槽系统的走向，XL-II系统设计有多种标准弯头，同时也可根据现场情况进行非标设计。

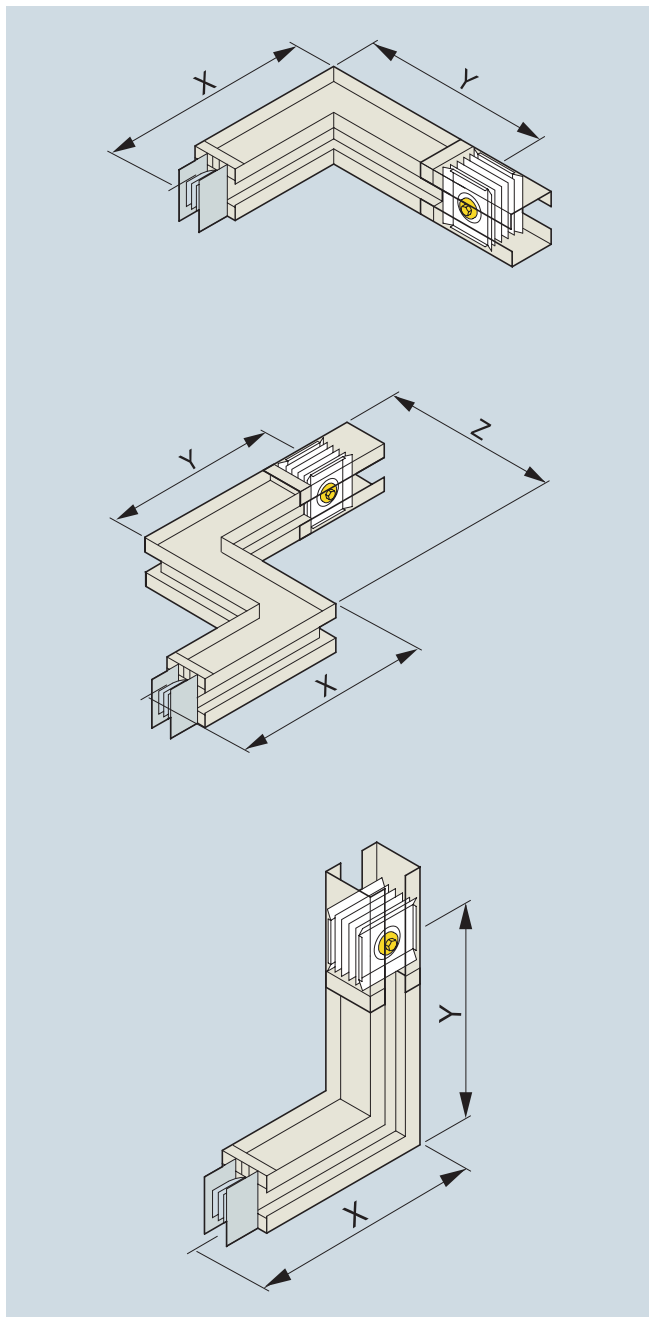

### Junction units

In order to change the direction easily, XL-II busbar system plans with multi standard junction units, and is available with non-standard planning according to site condition.

#### L型水平弯头(ER/EL) L Elbow (ER/EL)

标准长度	
XLC-II	X/Y = 0.35
标准长度	
XLA-II	X/Y = 0.50

#### 水平Z型弯头(RL/LR) Z unit (RL/LR)

标准长度	
XLC-II	X = 0.35m Y = 0.35m Z = 0.4m
标准长度	
XLA-II	X = 0.50m Y = 0.30m Z = 0.50m

#### L垂直弯头(FO/FI) L Knee (FO/FI)

标准长度	
XLC-II ... 01-05	X/Y = 0.35m
XLC-II ... 06-08	X/Y = 0.5m
XLC-II ... 09-11	X/Y = 0.8m
XLC-II ... 12	X/Y = 0.9m
标准长度	
XLA-II ... 01-04	X/Y = 0.40m
XLA-II ... 05-07	X/Y = 0.50m
XLA-II ... 08	X/Y = 0.60m
XLA-II ... 09-10	X/Y = 0.80m

# 功能单元

## 换向单元 Junction units

### 垂直 Z 型弯头(10/0) Z unit(10/0)

标准长度	
XLC-II ... 01-05	X/Y = 0.35m Z = 0.4m
XLC-II ... 06-08	X/Y = 0.5m Z = 0.5m
XLC-II ... 09-11	X/Y = 0.8m Z = 0.8m
XLC-II ... 12	X/Y = 0.9m Z = 1m
标准长度	
XLA-II .. 01-04	X/Y/Z = 0.40m
XLA-II .. 05-07	X/Y/Z = 0.50m
XLA-II .. 08	X/Y/Z = 0.60m
XLA-II .. 09	X/Y/Z = 0.80m
XLA-II .. 10	X = 0.80m Y = 0.90m Z = 0.80m

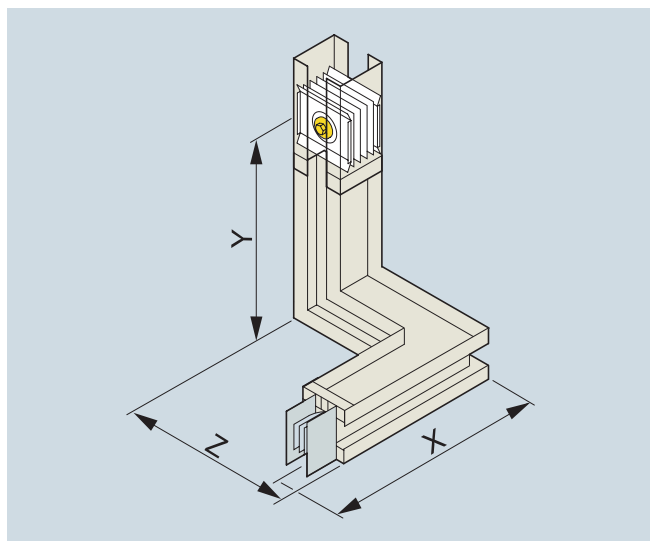
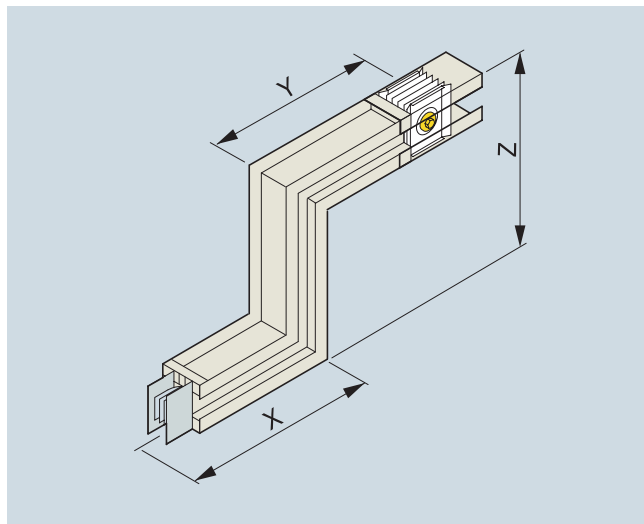

### 异型弯头(OL/IL) Offset unit (OL/IL)

标准长度	
XLC-II ... 01-05	X/Y = 0.35m Z = 0.4m
XLC-II ... 06-08	X = 0.5m Y = 0.35m Z = 0.5m
XLC-II ... 09-11	X = 0.8m Y = 0.35m Z = 0.8m
XLC-II ... 12	X = 0.9m Y = 0.35m Z = 0.9m
标准长度	
XLA-II .. 01-04	X = 0.50m Y/Z = 0.40m
XLA-II .. 05-07	X/Y/Z = 0.50m
XLA-II .. 08	X = 0.50m Y/Z = 0.60m
XLA-II .. 09-10	X = 0.50m Y/Z = 0.80m

### T型垂直弯头(TE) T Unit (TE)

标准长度	
XLC-II ... 01-05	X/Y/Z = 0.35m
XLC-II ... 06-08	X/Y/Z = 0.5m
XLC-II ... 09-11	X = Y = 0.6m Z = 0.8m
XLC-II ... 12	X = Y = 0.6m Z = 0.9m
标准长度	
XLA-II .. 01-04	X/Y = 0.35m Z = 0.40m
XLA-II .. 05-08	X/Y/Z = 0.50m
XLA-II .. 09-10	X/Y = 0.60m Z = 0.8m

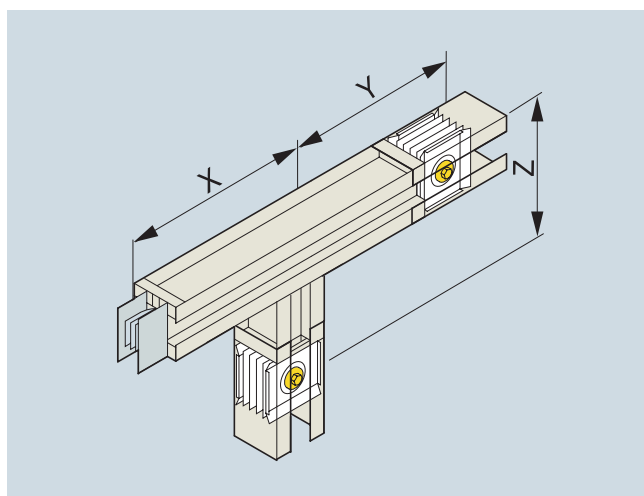

# 功能单元

## 与低压柜连接

### 与低压配电柜连接

我们提供专门的始端进线单元和完整的连接单元实现XL-II母线槽系统与配电柜的连接，连接时根据用户低压柜的具体出线方式进行调整设计，既可顶端出线，也可底端出线，电流最高达6300A，通常使用连接铜排进行转接，公司负责提供原材料及现场的指导安装，安装时保持现场连接最短路径及时间，进线单元中的始端母线配置有连接法兰，与设备密切结合，从而保证较高的防护等级。

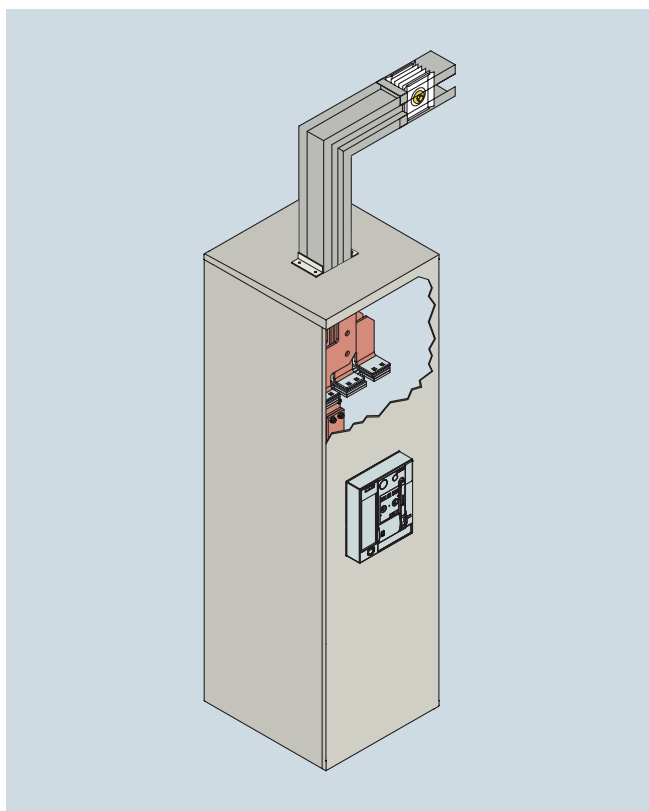

与西门子低压柜可直接对接

Connect directly with Siemens & Moeller low-voltage switchgear

### Connection with low-voltage switchgear

XL-II busbar system adopts the special entry-unit and integral connection unit to connect between busbar and switchgear. This connection can be made from above or below, thus ensuring flexible connections (max current 6300A). The copper connections are provided between busbar and switchgear. We offer the raw material and site installation instruction, ensuring the shortest connection and installation time. End flange in the feeder unit is collocated with connection flange to ensure a high protection degree.

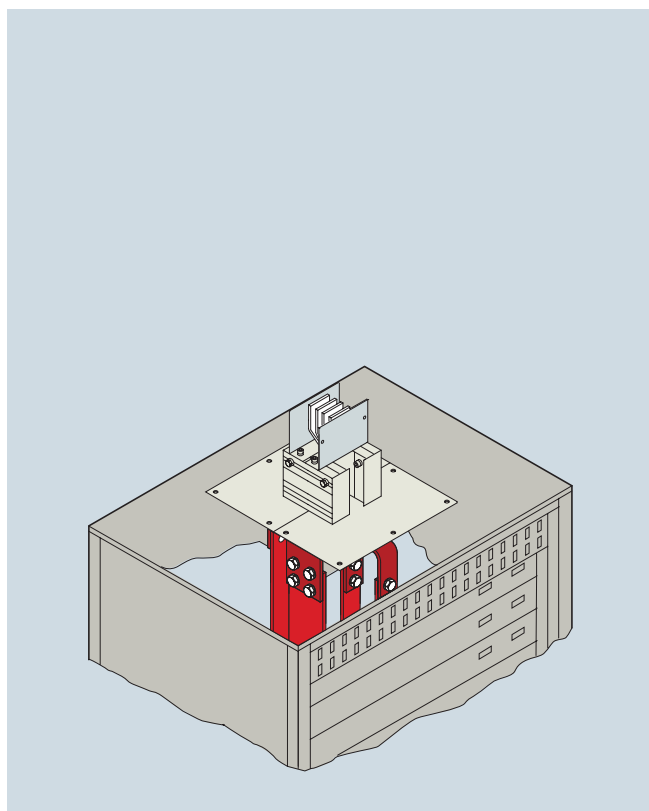

与其他柜型连接

Connect with other low-voltage switchgear

# 功能单元

## 与变压器连接

### 与变压器连接

XL-II母线槽提供完整的变压器连接AS单元，可与不同规格型号的变压器相连，最大电流可以达到6300A，并配备软连接，用于避免变压器运行时的微振造成紧固件的松动，从而影响到整个配电系统的运行，连接外形美观，安全可靠。我们可以按照变压器的具体出线方式进行调整设计，保持现场连接的最短路径和时间，同时提供单独的柜顶箱单元，以防止带电部件的裸露，提高系统的防护等级和安全性能。

### Transformer connection

XL-II busbar system provides AS unit to achieve connection with different types of transformers with the max current 6300A. The flexible part is planned to avoid screws loosening caused by microseism, enjoying nice appearance, safety and reliability. The special designing can be adjusted according to sequence and phase distance and to keep the shortest connection distance and installation time, meanwhile connection box is also provided to avoid the live parts exposed, largely improving the protection degree and safety performance.

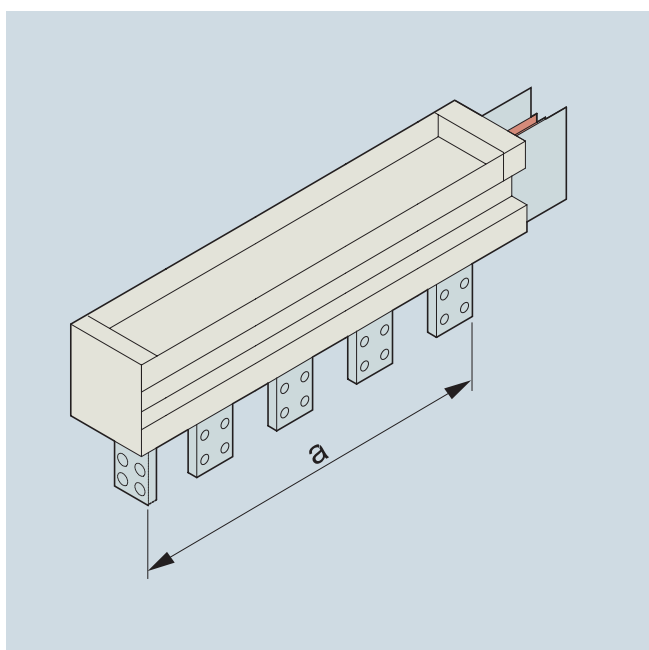

侧出线

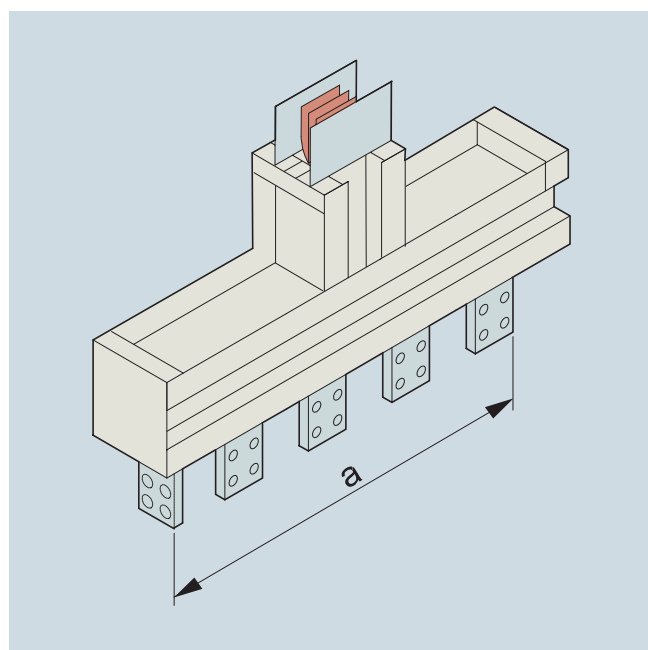

上出线

# 功能单元

## 电缆进线单元 Cable feeder unit

### 电缆进线单元

我们也提供单独的电缆进线单元用于实现与一段母线之间的馈电或受电或者在无需过电流保护的情况下使用的装置。电缆进线单元最大电流为5000A。

### 外形尺寸

最小尺寸:

460 mm x 640 mm x 630 mm (L x W x H)

最大尺寸:

1020 mm x 640 mm x 1120 mm (L x W x H)

多芯和单芯电缆都可以在电缆进线箱中使用，横截面不超过300mm<sup>2</sup>的电缆可直接安装使用。

电缆进线单元配备法兰板和电缆护套

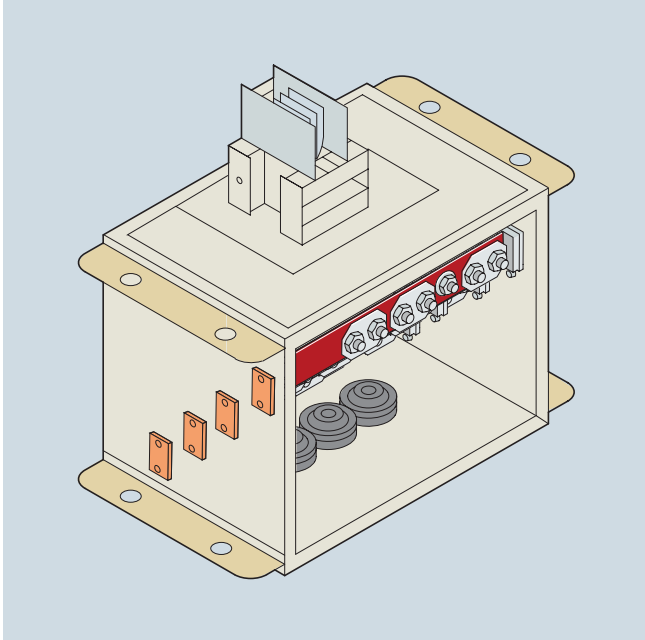

### Cable feeder unit

Cable feeder unit is used to achieve connection with one busbar unit when the busbar system has to be supplied via cables. Overall-dimension of cable feeder unit.

### Dimensions

Min. dimension:

460 mm x 640 mm x 630 mm (L x W x H)

Max. Dimension:

1020 mm x 640 mm x 1120 mm (L x W x H)

Both multi-core and single-core can be used in the cable feeder unit if only the cross-section of cable less than 300mm<sup>2</sup>.

Cable feeder unit is collocated with flange plate and cable sleeve.

# 功能单元

## 插接箱单元 Tap-off unit

### 插接箱单元

XL-II插接箱单元获得多项专利技术，其设计结构紧凑、外形美观、性能可靠，额定电流为16A~1250A，每种电流等级可提供5种不同外形尺寸，设计更贴切用户需求。

### 内部配置

根据用户对插接箱的配置要求，可以在插接箱内安装3极或4极断路器对负载进行保护，断路器可配备西门子3VT或3VL，也可由用户自行选择，包括保护开关的附件，比如操作手柄、分励脱扣、热磁脱扣、漏电保护模块等，公司将按照用户的要求提供标准配置。同时公司可以在现场测量后，参照现场具体情况对插接箱的外形尺寸进行非标设计，以满足现场的要求。

### 电缆馈线

插接箱通过电缆引出电流给负载进行供电，出线方式灵活，在电缆出线口配置有专门的电缆保护套管，保护套管的直径可以根据电缆的直径进行配置。

### 插口装置

母排无间隙，真正实现了高密度，具有低阻抗、散热快等特点，且通用性强，适用于不同导体配置系统。

母线系统的插口装置与导电桩头之间设有超声波塑料焊接固定的高弹性橡胶防护垫，防护等级高，确保插接时安全可靠。

### 插接方式

国际专利支持的“T”型插脚稳定、可靠，载流能力更强。

16-630A为单插口分接

800-1000A为双插口分接

1250A以上采用连接器分接

### 操作安全

防错相安装

提供IP54的防护等级

插脚均做镀银处理以保证系统可靠的电气连续性

插接箱内部多重连锁，防止在通电情况下插接箱门被打开，进一步保证了操作人员的人身安全。



## Tap-off unit

Tap-off unit of XL-II busbar system gains many patents, enjoying structure compact, nice appearance, reliable performance. The rated current is 16A-1250A, 5 different dimensions as per current rating. The design is closer to users.

### Inside configuration

3 pole or 4 pole breaker is collocated according to user's requirements. The breaker is optional for SIEMENS 3VT or 3VL or the other brand as well, including the switch accessories, e.g. operating handle, protection, shunt release (trips) ST, thermal-magnetic trip, leaking protection. In the meantime special design on sizes of tap-off units can be make according to site details after site measurements.

### Cable connection

The tap-off unit supplies power to loading equipments with flexible outputting line collocated with protection sleeves. The diameter depends on the cable size.



## Tap-off point

Tap-off point of XL-II busbar system truly achieves high compact structure, low impedance and universal application for different kinds of conductor configuration. High elastic rubber protective pad fixed by Ultrasonic Plastic Welding is planned between tap-off device and conductor, ensuring high level of protection, safe and reliable plugging.

### Plugging method

International Patent supported T-pins ensure stable, reliable and large current-loading capacity.

16A to 630A is single side tapping;

800A to 1000A is double sides tapping;

1250 and above is joint pack connection.

### Safe operation

Anti-wrong installation;

Protection degree of IP54;

Silver-plated plug feet ensure reliable electrical continuity;

Multi inter-lock prevents plugging on loading.



# 功能单元

## 连接器单元

### “QWIKMAKE”™ 连接器 国际专利支持

摒弃了传统的设计，使得安装速度较普通连接器快一倍。而且由于它不可翻转，两段母线在连接时不会发生错相，简化安装程序，更有助于安全快速的安装。

### 双头力矩螺栓

该通用件从英国原装进口，双头螺钉能保证在安装时，只需19mm普通扳手旋紧螺钉直至上面的螺栓头自动断裂，且螺钉上的黄色指示牌脱落，说明该接头力矩已达到最佳状态，可节约75%安装时间。安装完毕后剩余的螺栓头可在维修、拆装时二次利用。

### 高压力均衡垫

螺栓锁紧时产生的压力通过特殊设计的碟型垫圈传递至与铜排等截面的高压力均衡垫，确保整个母线连接处面压力均匀、松紧适度，电气连接安全可靠。

### 膨胀补偿

接头的设计(对接式)满足由于热膨胀而引起母线槽的线性伸缩，在不降低母线的机械强度、电气连续性、载流容量及短路流量的前提下，每个连接器提供7mm的膨胀补偿，使得XL-II 母线槽系统在实际应用中无需安装特殊的膨胀节单元。

### 防护等级高

连接器各零部件之间均设计有防水措施，同时加有绝缘垫的连接盖板使得在母线连接处也能保证较高的防护等级。



### International patent acquired “QWIKMAKE” TM joint pack

By abandoning the traditional design, its installation speed is twice faster than ordinary connector. But also because it can not be overturned, wrong phase operation won't occur when connect two busbar units, simplifying the installation procedure, contributing to the rapid and safe installation.

### Double-headed torque bolt

The universal bolts are imported from UK. Only 19mm ordinary wrench than torque spanner is needed to tighten until the outside head as well as the yellow plate breaking off, which means the torque of the joints have reached the best condition. 75% time is saved. After installation, the rest head bolt can be reused in later maintenance and disassembly.

### High pressure balanced clamp

The pressure caused by bolt locking passes to the balanced clamp (the same section as copper) through a specially designed butterfly gasket, ensures that the appropriate pressure, uniform elastic, safe and reliable electrical continuity at system joints.

### Compensation for expansion

Joint pack (butt type) of XL-II busbar system meets linear expansion due to thermal expansion. Under the premise of never lowering the mechanical strength, electrical continuity, current-loading capacity and short-circuit capacity. Each joint pack is provided 7mm compensation for expansion, making the XL-II busbar system never need to collocate with any special expansion unit.

### High protection degree

Each part and component of joint pack is designed with waterproofing measures. Meanwhile, joint pack cover guarantees a higher level of protection.

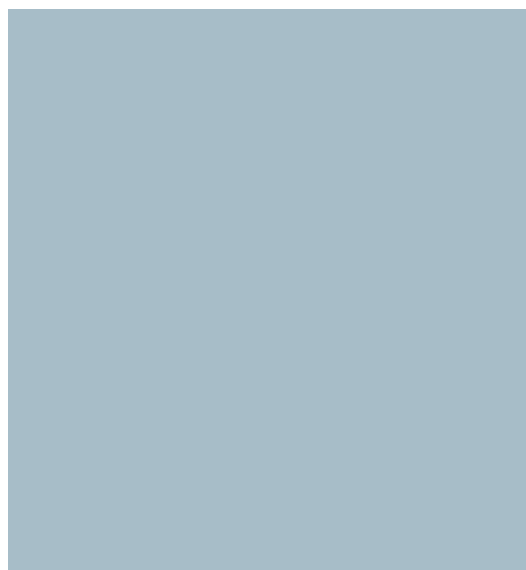

# 功能单元

## 系统附件

### 终端单元

母线终端安装在母线槽系统的末端，用以防止导电部件的裸露。

#### End cap

End cap is mounted in the end to avoid exposing of conductors.

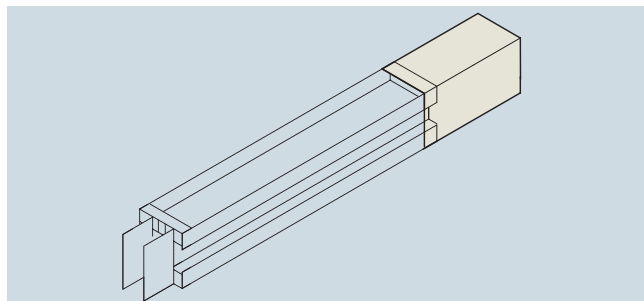

### 垂直安装支架

母线槽垂直安装时提供特殊的弹簧支撑件作为安装附件，每个弹簧支撑架都能承受母线及插接箱所带来的额外载重负荷。

#### Vertical installation

Special spring supports are available as installation accessories if requested.

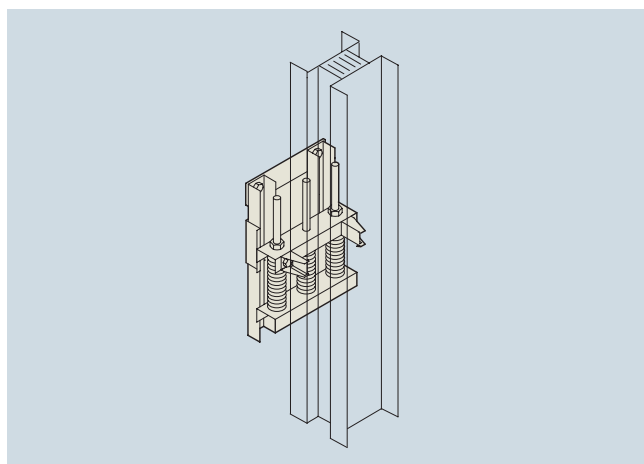

### 水平安装支架

提供两种不同的安装支架

水平立装使用

水平侧装使用

安装支架上自带的定位装置能固定母线槽系统，使得安装好的系统更加稳固，同时这种定位装置是跟安装支架一起提供的。

#### Horizontal mounting supports

two different mounting devices are available

For horizontal flatwise

For horizontal edgewise

Clamps in the supports which make busbar trunking system stably are available if requested.

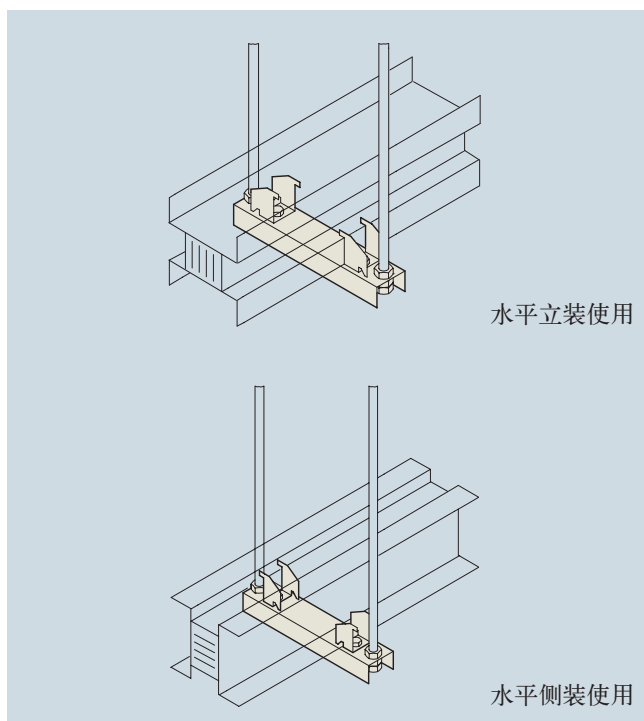

# 物理数据

## Physical data

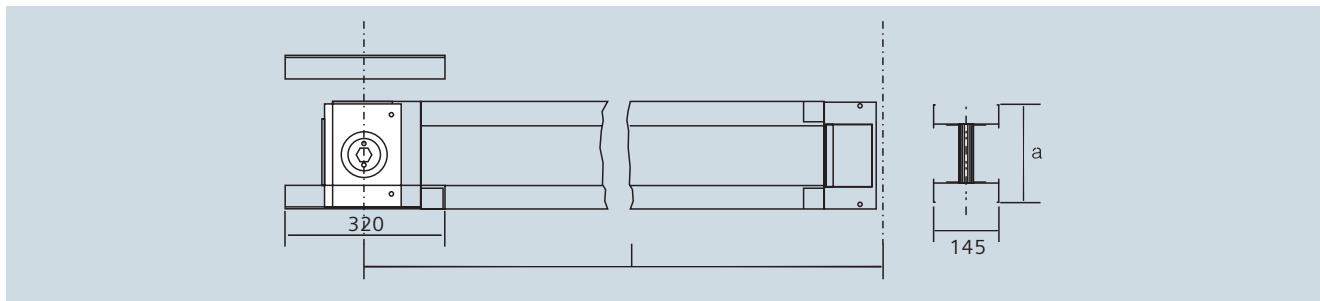

单排系统

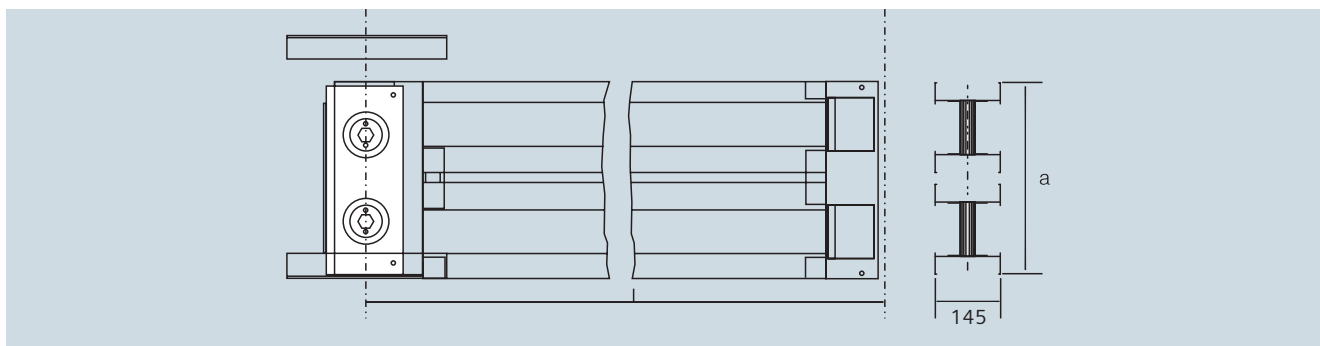

双排系统

## 直线段单元

系统	a/mm	系统	a/mm
XLC-II 400A	114	XLC-II 2000A	199
XLA-II 400A	114	XLA-II 2000A	373
XLC-II 630A	114	XLC-II 2500A	244
XLA-II 630A	119	XLA-II 2500A	443
XLC-II 800A	114	XLC-II 3150A	373
XLA-II 800A	134	XLA-II 3150A	533
XLC-II 1000A	119	XLC-II 4000A	443
XLA-II 1000A	164	XLA-II 4000A	613
XLC-II 1250A	134	XLC-II 5000A	533
XLA-II 1250A	199	XLA-II 5000A	/
XLC-II 1600A	164	XLC-II 6300A	613
XLA-II 1600A	244	XLA-II 6300A	/

# 物理数据

## Physical data

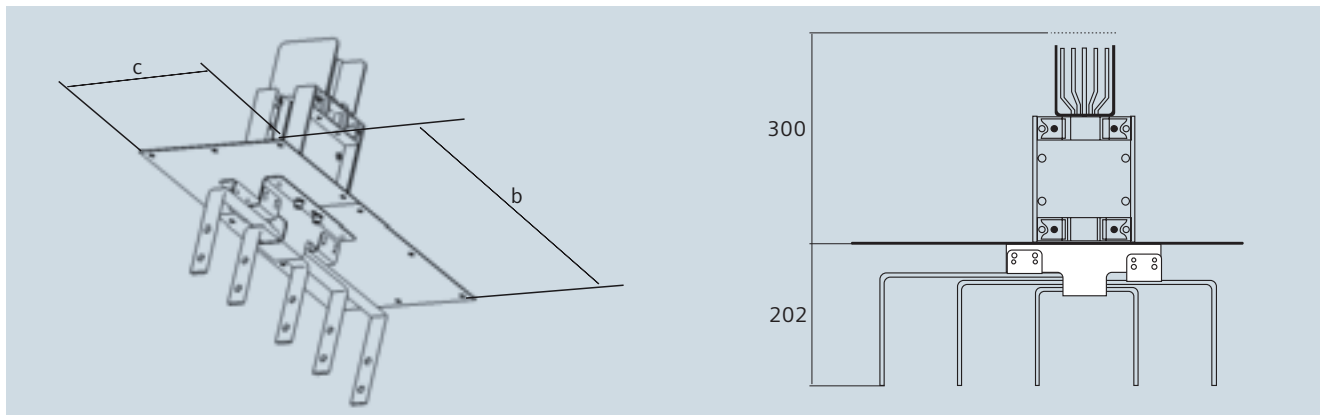

## 始端单元

系统	b/mm	c/mm
XLC-II 400A	555	280
XLA-II 400A	555	280
XLC-II 630A	555	280
XLA-II 630A	555	285
XLC-II 800A	555	280
XLA-II 800A	555	300
XLC-II 1000A	555	285
XLA-II 1000A	555	330
XLC-II 1250A	555	300
XLA-II 1250A	555	365
XLC-II 1600A	555	330
XLA-II 1600A	555	410
XLC-II 2000A	555	365
XLA-II 2000A	555	539
XLC-II 2500A	555	410
XLA-II 2500A	555	609
XLC-II 3150A	555	539
XLA-II 3150A	555	699
XLC-II 4000A	555	609
XLA-II 4000A	555	819
XLC-II 5000A	555	699
XLA-II 5000A	555	/
XLC-II 6300A	555	819
XLA-II 6300A	555	/

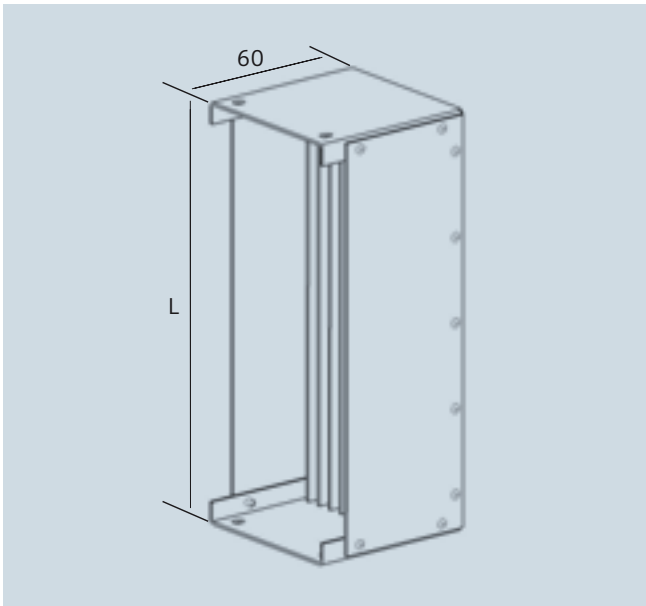
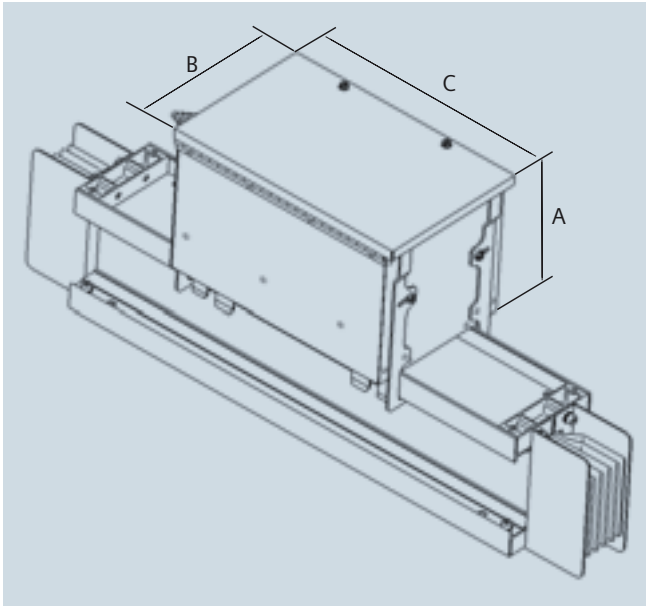

### 插接箱单元

保护单元	电流 (A)	A/mm	B/mm	C/mm
断路器 (西门子 3VT)	16 - 100	220	230	360
	125 - 160	250	250	400
	200 - 250	270	270	500
	315 - 400	310	310	650
	630	340	340	850
	800	350	420	1250

### 终端

系统	L/mm
XLC-II 400A	122
XLA-II 400A	122
XLC-II 630A	122
XLA-II 630A	127
XLC-II 800A	122
XLA-II 800A	142
XLC-II 1000A	127
XLA-II 1000A	172
XLC-II 1250A	142
XLA-II 1250A	207
XLC-II 1600A	172
XLA-II 1600A	252
XLC-II 2000A	207
XLA-II 2000A	381
XLC-II 2500A	252
XLA-II 2500A	451
XLC-II 3150A	381
XLA-II 3150A	541
XLC-II 4000A	451
XLA-II 4000A	621
XLC-II 5000A	541
XLA-II 5000A	/
XLC-II 6300A	621
XLA-II 6300A	/

# 其他

## 计算及选型

### 计算及选型

#### 额定电流的计算

在安排母线槽系统布局时须注意以下几点：

- 负载或配电系统的场所、数量和连接方式
- 分散系数
- 设定的短路等级

#### 与配电柜连接须提供

- 配电柜的型号
- 进线方式（顶端、底端或背面）

#### 安装的地理位置和条件

- 空间尺寸
- 建筑物构造（针对悬挂和安装）
- 母线槽走向
- 环境条件（温度、湿度、空气质量等）
- 系统穿过的墙面

与其他系统配套—比如与母线槽系统安装配套的部分为：

- 供电线路的平面图
- 通风管道走向的位置
- 照明系统的平面图
- 需提供插接单元的数量和具体位置
- 母线槽系统严格按照上面提到的几点进行测量，第一步是计算额定电流。

### PRODUCTS

#### Calculating the rated current

The following information is important for planning busbar trunking for transporting and distributing power

- Location, number and connected loads of the consumers or subdistribution systems
- Rated diversity factor
- Information on the short-circuit level to be expected

#### Information on distribution board to be supplied

- Distribution board type
- Supply (top, bottom, rear)

#### Type and structure of copper busbars

- Spatial dimensions
- Building structure (for suspension and fixing)
- Transportation paths
- Ambient conditions (temperature, humidity, dirt, etc.)
- Wall cut-outs

#### Coordination with other system sections - for example, required coordination with the busbar trunking

- system installation plan
- With planned power lines
- With the planned locations of ventilation duct runs
- With lighting plans
- Required number and location of the tap-off points

$$I_B = \frac{P_{inst} \cdot \alpha \cdot b}{\sqrt{3} \cdot U_e \cdot \cos\phi} \cdot 10^3$$

$I_B$  = 额定电流(A)

$U_e$  = 额定工作电压(V)

$\cos\phi$  = 功率因数

$P_{inst}$  = 安装功率

$\alpha$  = 分散系数

$b$  = 馈电系数

$b=1$  单面馈电

$b=0.5$  双面馈电和中间馈电单元

The busbar trunking system is dimensioned taking into account the restrictions mentioned above. The first step is to determine the rated current.

$I_B$  = Rated current (A)

$U_e$  = Rated operational voltage (V)

$\cos\phi$  = power factor

$P_{inst}$  = Installed power (KW)

$\alpha$  = Diversity factor

$b$  = Feeder factor

$b = 1$  with single-ended feed

$b = 0.5$  with double-ended feed and centre feeder unit

主电路数	$\alpha$
2 与 3	0.9
4 与 5	0.8
6 至 9	0.7
10 及以上	0.6

除非特殊规定，一般情况下  $\alpha$  都表示分散因数，这点可以参照 IEC/EN 60439-1 标准

载荷容量与环境温度的关系。

额定电流  $I_e$  是基于一定的环境温度而言的(24小时平均温度为 35°C，不超过 40°C，右面的图表就表明了载荷容量是随着环境温度的变化而变化的。

Frequently the diversity factor as per IEC/EN 60 439-1(see table) can be used for unless this is ruled out by particular application.

Dependence of load-carrying cappacity on the ambient temperature.

The rated current  $I_e$  is based on an ambient temperature of 35 celsiue.

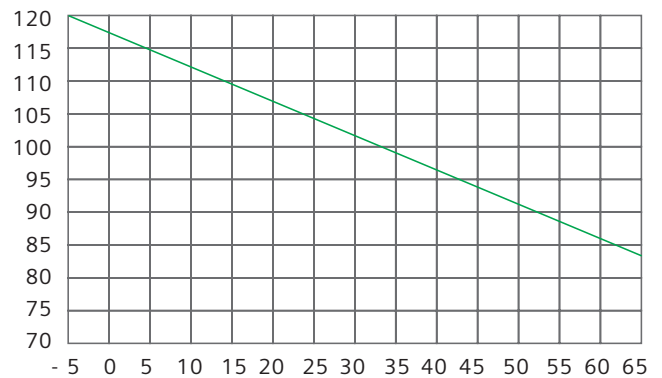

# 其他

## 设计实例

### 电压降的计算

如果母线槽系统长距离输配电，就必须考虑到电压降对系统的影响，下面是电压降的具体计算公式：

$$\Delta U = a \cdot \sqrt{3} \cdot I_B \cdot l \cdot (R' \cdot \cos\phi + X' \cdot \sin\phi) \cdot 10^{-3}$$

$\Delta U$  =电压降(V)

$I_B$  =额定电流(A)

$l$  =系统总长度(m)

$a$  =载荷分配系数日

$R'$  =电阻(mΩ/m)

$X'$  =电抗(mΩ/m)

$\cos\phi$  =功率因数

For long busbar lines, it may be necessary to calculate the voltage drop.

$$\Delta U = a \cdot \sqrt{3} \cdot I_B \cdot l \cdot (R' \cdot \cos\phi + X' \cdot \sin\phi) \cdot 10^{-3}$$

$\Delta U$  = voltage drop(V)

$I_B$  = rated current(A)

$l$  = total length of the system(m)

$a$  = load distribution factor

$R'$  = resistive load(m /m)

$X'$  = inductive load(m /m)

$\cos\phi$  = power factor

载荷分配系数须根据载荷分配的类型而定，下面的图表反映了在额定电流一定的情况下载荷分配的不同方式。

Factor a used in the equation for calculating the voltage drop is dependent on the load distribution.

载荷分布		系数 A
A → B ↓	从A供电 B点插接配电	1
A → B ↓ C ↓ D ↓ E ↓	A点供电 B、C、D、E插接配电	0.5
B ↓ A ↑ C ↓	从A供电 B、C点插接配电	0.25
B ↓ D ↓ A ↑ E ↓ C ↓	A点供电 B、C、D、E插接配电	0.125

最小单极接地故障电流的安全断开回线阻抗决定了一极短路电流的大小，需要计算：

相线导体和保护导体

相线导体和PEN导体之间的回线阻抗

阻抗值主要取决于：

检测结果

计算结果

模拟系统

The loop impedance determines the size of the 1-pole short-circuit current. The loop impedance is calculated between the phase conductor and protective conductor  
Phase conductor and PEN conductor

This value may be determined by

Measuring with measuring instruments

Calculation

Simulating the network in the network model.

技术参数表中已经详细列明了XL-II母线槽系统的阻抗值，因此可以根据阻抗值计算母线槽系统的回线阻抗，从而得到系统的总回线阻抗值。

通过整个母线槽系统的回线阻抗，很容易估算系统的1极最小短路电流，或通过计算得到。

The Technical Data includes a listing of the impedance values of the XL-II busbar trunking system so that you can calculate the loop impedances of a busbar system which forms part of the total loop impedance.

With the aid of the loop impedance of the entire busbar trunking system it is easy to calculate the smallest 1-pole short-circuit current which can be expected.

$$I_{k1min} = \frac{c \cdot U_n}{\sqrt{3} \cdot Z_k}$$

$c$  = 电压系数 0.95

$U_n$  = 相间电压

$Z_k$  = 阻抗

## 过载及短路保护

母线槽系统在运行时必须进行过载及短路保护，通常情况下熔断器或断路器都是作为保护装置而在系统中广泛使用。选择时，需考虑短路电流的强度、系统的运行功能等因素。

在实际应用中由于熔断器的灵敏度非常高，而且当电流稍微超过额定电流时，熔断器就开始熔化，但熔化的时间比较长，所以熔断器不是很适合作为过载保护装置在系统中使用

若母线槽系统的过载保护装置使用熔断器，为了保证保护装置对母线槽系统提供合适的保护，熔断器的额定电流必须要比母线槽系统的额定电流低一个等级。

如果使用断路器进行保护，其保护单元可以根据母线槽系统的额定电流进行调整，也就是说母线槽系统可以达到 100% 的载流量。

若决定采用熔断器和断路器作为保护装置对母线槽系统进行短路保护时，所选型号的电流不要超过母线槽系统指定的保护电流，还需考虑短路电流的强度、是否需要带限流保护装置及所选保护装置的短路开关容量是多少等因素。

如下：

$$I'' \leq I_{cc} \leq I_{cu}$$

$I''k$  = 估计的安装位置的短路电流

$I_{cc}$  = 系统运行时的额定电流

$I_{cu}$  = 断路器的额定短路容量

## Overload and short-circuit protection

Busbar trunking systems must be protected against short-circuits and overloads. Fuses and circuit-breakers are used as protective devices.

When selecting these protective devices, the strength of the expected short-circuit currents, selectivity requirements, operating and signalling functions may also be factors in your decision.

Fuses are in general less suitable as overload protection on account of their relatively high response characteristics (1.3 to 1.6 times the rated current) and their long melting time with small over-currents.

To ensure adequate protection of the busbar trunking system against overloads using a fuse, its rated current must be a step lower than the rated current of the busbar trunking system which is to be protected. This means that the busbar trunking system may not necessarily be used optimally.

If circuit-breakers are used, the thermally delayed overload release must be set to the value of the rated current of the busbar trunking system. This means that the busbar trunking system can be loaded 100%.

When you decide on your short-circuit protection via fuses and circuit breakers you must not exceed the specified short-circuit ratings of the busbar trunking systems. It will depend on the strength of the short-circuit current expected whether a current-limiting protective device is required and what short-circuit breaking capacity the protective device should have.

A tabular overview is provided below of the circuit-breakers which can provide short-circuit and overload protection (400V and 50Hz) for the corresponding trunking system.

The following applies:

$$K \leq I_{cc} \leq I_{cu}$$

$k$  = the short-circuit current expected at the place of installation

$I_{cc}$  = conditional rated short-circuit current of the busbar run

$I_{cu}$  = rated short-circuit breaking capacity of the circuit breaker

# 其他

## 设计实例

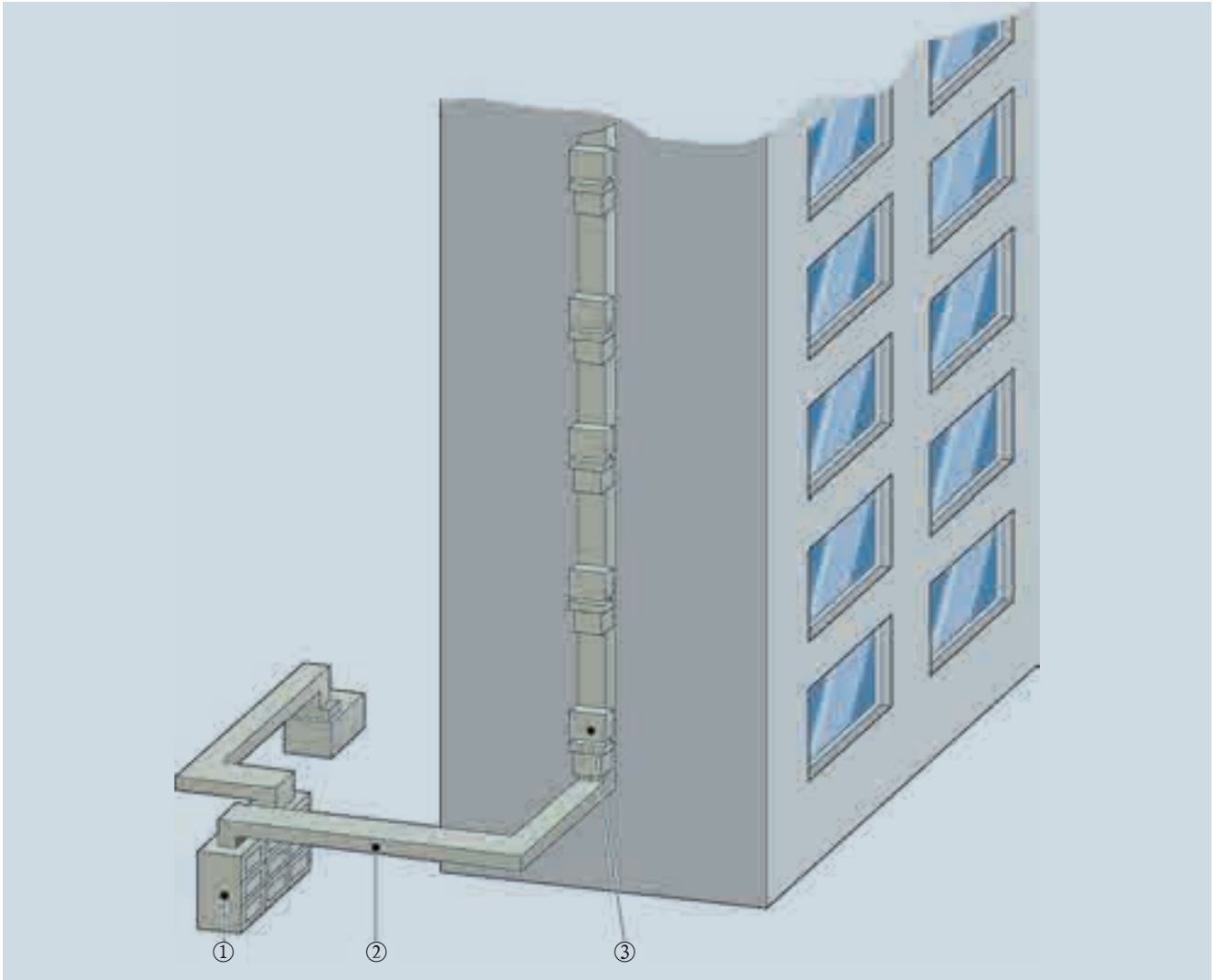

1	配电柜
2	母线槽系统
3	插接箱

1	Power distribution board
2	Busbar trunking system
3	Tap-off point

楼层数	10 层 (每层 8 个房间)
每间房额定值	26KW
额定工作电压 $U_e$	400V
功率因数 $\cos(\text{符号})$	0.9
分散因数(符号)	0.6
利用系数(符号)	0.5
变压器供电	1×1250KVA, $U_k=6\%$
防护等级	IP54
系统型式	TN-S

## 每层楼额定电流的计算

$$I_{BS} = \frac{P_{inst} \cdot \alpha}{\sqrt{3} \cdot U_e \cdot \cos\phi} \cdot 10^3$$

$I_{BS}$  = 每层楼的额定电流 (A)

$U_e$  = 额定工作电压 (V)

$\cos\phi$  = 功率因数

$P_{inst}$  = 安装功率 (KW)

$\alpha$  = 功率因素

$$I_{BS} = \frac{8 \cdot 26 \cdot 0.6}{\sqrt{3} \cdot 400 \cdot 0.9} \cdot 10^3 = 200A$$

## 直线段额定电流的计算

$$I_B = (I_{NS} \cdot \beta)$$

$$I_B = 10 \cdot 200 \cdot 0.5 = 1000A$$

换算系数是总负载数的利用和分散系数，如果不知道具体的换算系数，可以咨询当地的供电公司，供电公司有详细的不同场合下的换算系数值。下面的图表列出了换算系数的平均值：

The reduction factor is the utilization and rated diversity factor for the total number of loads. If no precise figures are known, good typical values can be obtained from the local power companies. They do however vary regionally. The table shows average values:

用户类型	$\beta$
电炉室或蒸汽炉室	0.1-0.2
商业性的办公场所和建筑的照明	0.7-0.9
电梯和服务设施	0.6-0.8
会议室	0.6-0.8
小型办公场所	0.5-0.7
大型办公场所	0.4-0.8

从上面提到的几点，我们可以很容易就进行XL-II母线槽系统的选择，例如：需三相五线制系统，100%中性线，所承载的电流为1250A，而相应的短时耐受电流为50KA。

母线槽系统为：XLC-II 0551

插接箱单元：箱体规格为2#、母线系统为51、防护等级为IP54的插接箱，采用断路器保护并带有旋转操作手柄，断路器为3极、额定电流为250A。

插接箱单元代码为：XL-2AK51M/LSH-250S-3

The collated results lead to the selection of an XL-II busbar system, 5-conductor with full N conductor cross-section, a current carrying capacity of 1250A and a short-circuit rating of  $I_{cw}(t=1s)$  50kA.

Busbar System: XLC-II 0551

tap-off box specification is 2#, busbar system is 51, IP54, breaker protection and Rotary operating handle, breaker is 3 poles, and rated current is 250A.

Tap-off unit code: XL-2AK51M/LSH-250S-3

# 其他

## 母线槽系统的安装

下列图示表明了母线槽单元穿墙安装时的标准尺寸

Charts below shows the standard dimensions while installation through walls.

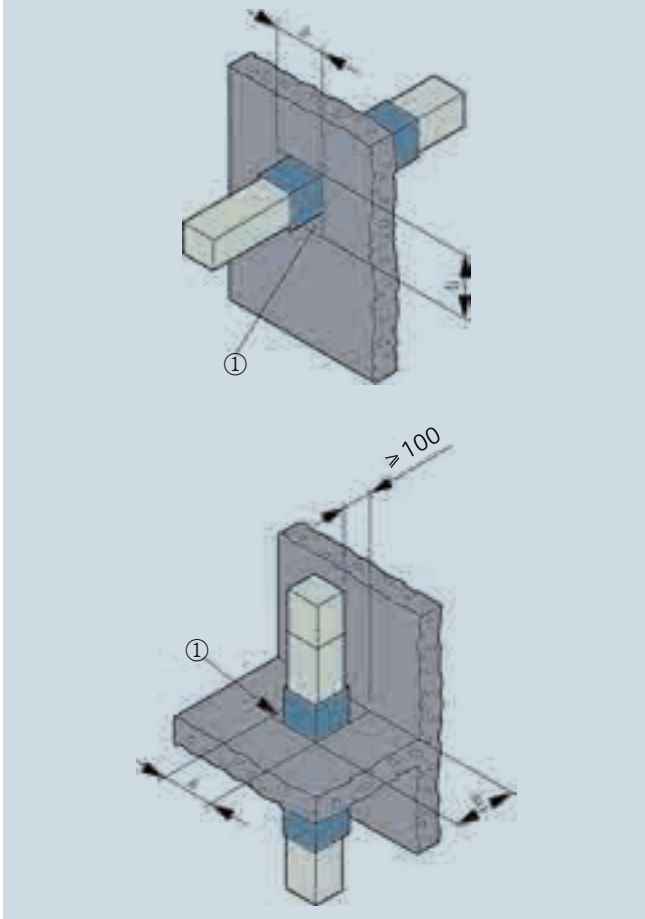

电流 A	a/mm	b/mm
XLC-II 400A XLA-II 400A	350	320
XLC-II 630A XLA-II 630A	350	325
XLC-II 800A XLA-II 800A	350	340
XLC-II 1000A XLA-II 1000A	350	370
XLC-II 1250A XLA-II 1250A	350	405
XLC-II 1600A XLA-II 1600A	350	450
XLC-II 2000A XLA-II 2000A	350	580
XLC-II 2500A XLA-II 2500A	350	650
XLC-II 3150A XLA-II 3150A	350	740
XLC-II 4000A XLA-II 4000A	350	860
XLC-II 5000A XLA-II 5000A	350	/
XLC-II 6300A XLA-II 6300A	350	/

### 水平安装尺寸要求

为了使母线槽系统和插接箱单元的安装更加简单方便，在进行设计时必须考虑到系统安装的最小尺寸。

XL-II 母线槽系统 (不带插接箱)

XL-II 馈电式母线槽系统的最小尺寸

Requirements of dimensions for horizontal installation

To ensure convenient installation of busbar trunking units and tap-off

units your design work should take into account the recommended distances from building components.

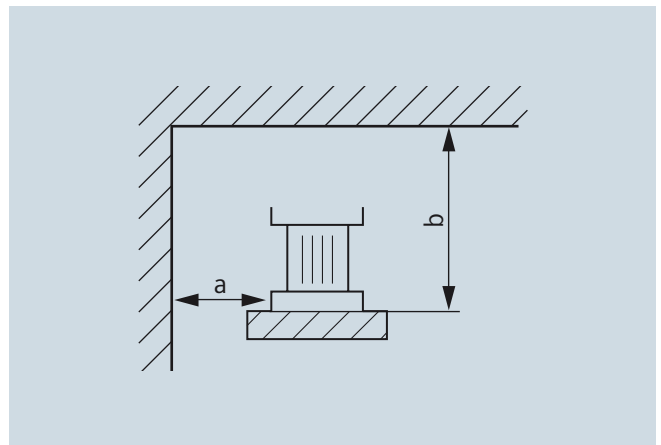

### XL-II 母线槽系统 (带插接箱)

#### XL-II 馈电式母线槽系统的最小尺寸

Min. dimensions for XL -II busbar trunking without tap-off units

Min. dimensions for XL -II busbar trunking with tap-off units

### 垂直安装尺寸要求

#### XL-II 母线槽系统(不带插接箱)

下面的图示表明了母线槽系统安装时的最小尺寸, 并没有反映安装附件的尺寸, 在工程项目中安装时要充分考虑到。

#### Requirements of dimensions for vertical installation XL -II busbar trunking without tap-off units

Min. dimensions for busbar trunking systems without tap-off units. The dimensions of system fixing brackets not shown in the diagram have been taken into account.

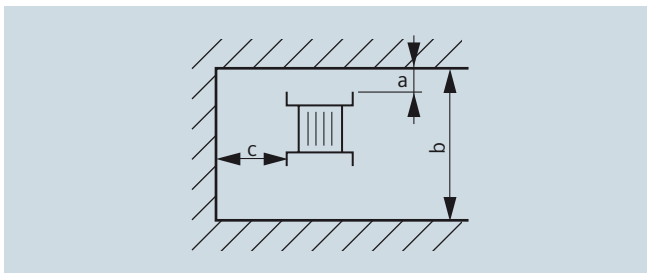

水平安装		XLC-II	XLA-II		XLC-II	XLA-II
	a	b	c		d	
400	100	214	214	350	914	914
630	100	214	219	350	914	919
800	100	214	234	350	914	934
1000	100	219	264	350	919	964
1250	100	234	299	350	934	999
1600	100	264	344	350	964	1044
2000	100	299	473	350	999	1173
2500	100	344	543	350	1044	1243
3150	100	473	633	350	1173	1333
4000	100	543	713	350	1243	1413
5000	100	633		350	1333	
6300	100	713		350	1413	

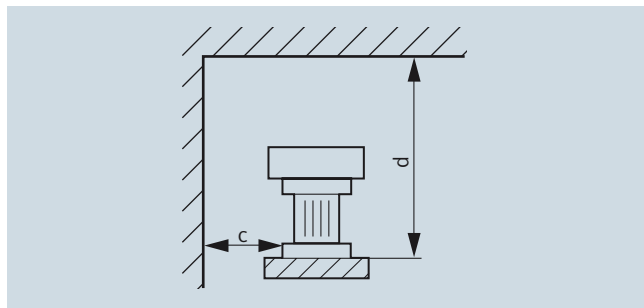

#### XL-II 母线槽系统(带插接箱)

下面的图示表明了母线槽系统安装时的最小尺寸, 并没有反映安装附件的尺寸, 在工程项目中安装时要充分考虑到。

#### XL-II busbar trunking with tap-off units

Min. dimensions for busbar trunking systems with tap-off units. The dimensions of system fixing brackets not shown in the diagram have been taken into account.

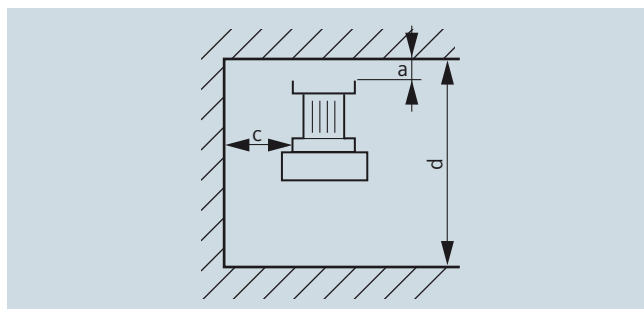

垂直安装		XLC-II	XLA-II		XLC-II	XLA-II
	a	b	c		d	
400	100	314	314	50	1014	1014
630	100	314	319	50	1014	1019
800	100	314	334	50	1014	1034
1000	100	319	364	50	1019	1064
1250	100	334	399	50	1034	1099
1600	100	364	444	50	1064	1144
2000	100	399	573	50	1099	1273
2500	100	444	643	50	1144	1343
3150	100	573	733	50	1273	1433
4000	100	643	813	50	1343	1513
5000	100	733		50	1433	
6300	100	813		50	1513	

# 其他

## 母线槽系统的安装

### 安装方式

母线槽系统垂直安装时，对于插接箱的安装方式有着明确的规定，需采用底出线的方式，当L1导体在左手侧的时候，插接箱也要采用底出线的安装方式。

### 垂直安装

当XL-II母线槽垂直安装时需要特殊的安装附件(弹簧支架)，而且如果是单套系统，每层楼则至少需加装一套弹簧支架装置，如果是双套系统，则至少需要加装两套弹簧支架装置，弹簧支架的作用主要是为了承载母线槽自身的重量及运行时产生的线性膨胀有两种不同的规格型号可供选择，在选择时要考虑到插接箱所带来的额外重量，同时对于输电母线和配电网线要有区别，针对不同的母线槽型号进行不同的选择。

### Mounting position

The mode of installation is prescribed for tap-off units with vertical busbar runs. The tap-off cable must be connected from below. This will be the case when the L1 conductor is on the left-hand side(as seen from the front).

### Vertical fixing

Speccial spring brackets are required for installing vertical XL-II busbar runs. Per storey at least one bracket should be used for single systems and two bracket for double systems. The spring bracket is designed to carry and secure the inherent weight and the linear extension of the busbar trunking systems load. Two versions with different dimensions and spring force are available for this. In order to allow for the additional weight of tap-off units, type selection should distinguish between power transmission and power distribution.

	电流 A	数量
输电	400 ~ 2500	1
	3150 ~ 6300	2
配电	400 ~ 2500	1
	3150 ~ 6300	2

注：每层楼至少一套插接箱单元 ④ 防火栅

① 终端

② 插接箱单元

③ 弹簧支架

⑤ 天花板厚度

⑥ 安装支架距离墙面需10cm

⑦ 配电柜

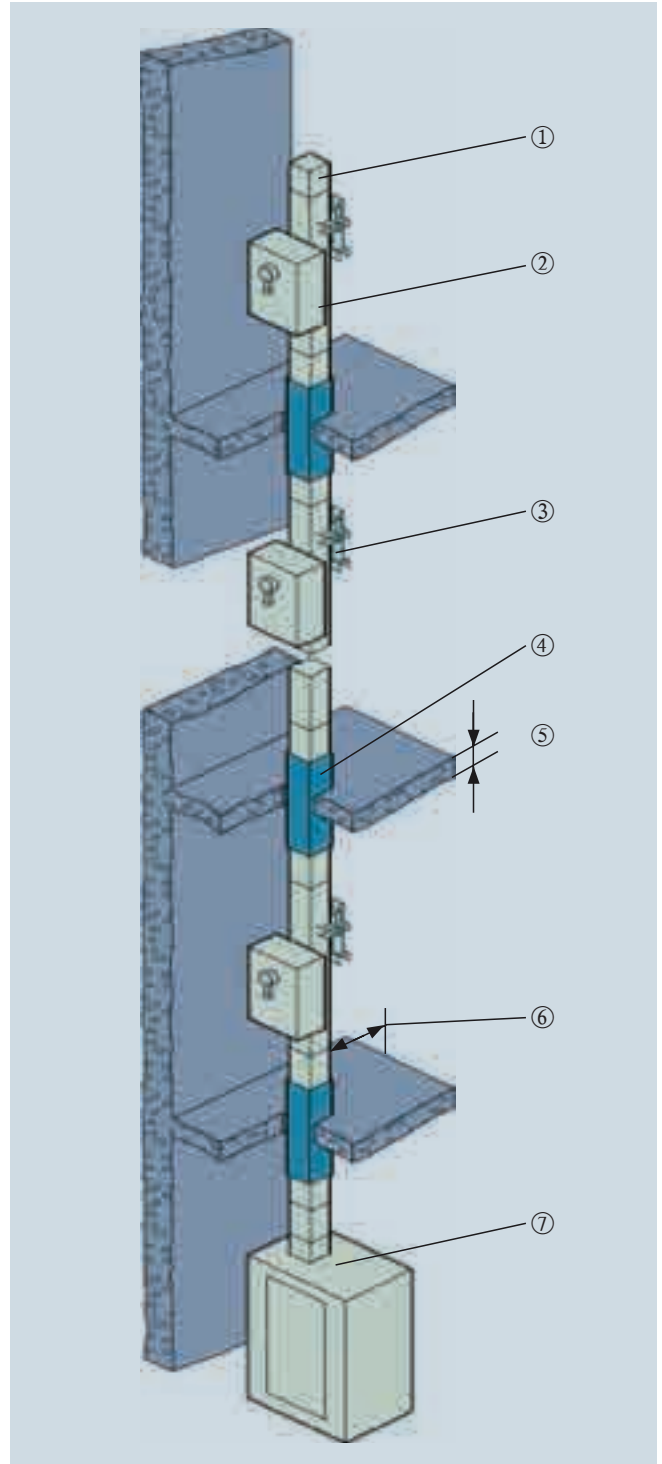

垂直安装的母线槽走向图

吊顶吊装

单排  
Single bar

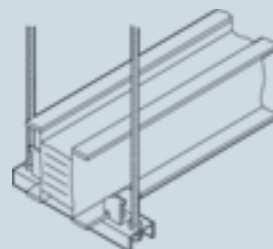
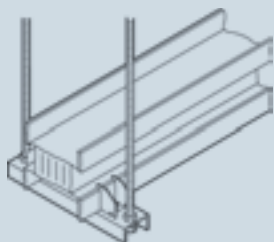

双排  
Double bar

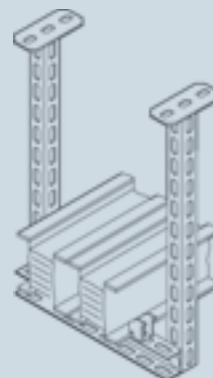
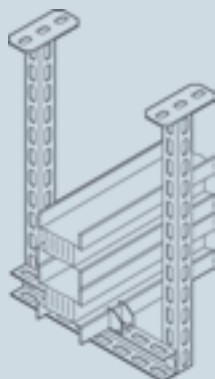

支架支撑

单排  
Single bar

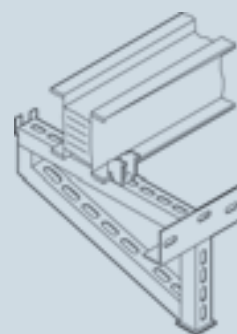
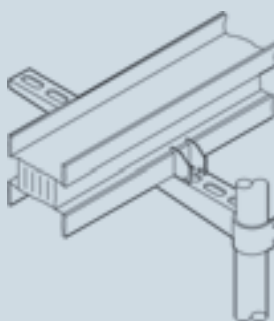

双排  
Double bar

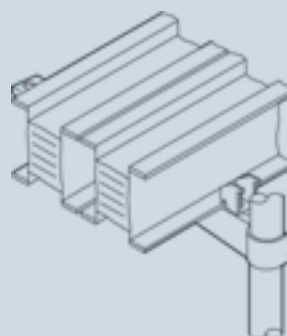
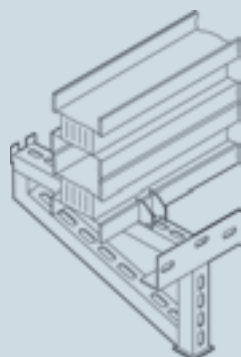

## 华北区

### 北京

北京市朝阳区望京中环南路7号  
邮编: 100102  
电话: (010) 6746 8888  
传真: (010) 6476 4813

### 天津

天津市和平区南京路189号  
津汇广场写字楼1401室  
邮编: 300051  
电话: (022) 8319 1666  
传真: (022) 2332 8833

### 唐山

河北省唐山市建设北路99号  
火炬大厦1308室  
邮编: 063020  
电话: (0315) 317 9450  
传真: (0315) 317 9733

### 石家庄

河北省石家庄市中山东路303号  
世贸广场酒店1309室  
邮编: 050011  
电话: (0311) 8669 5100  
传真: (0311) 8669 5300

### 太原

山西省太原市府西街69号  
国际贸易中心西塔1609B  
邮编: 030002  
电话: (0351) 868 9048  
传真: (0351) 868 9046

### 呼和浩特

内蒙古自治区呼和浩特市  
乌兰察布西路内蒙古饭店1508房间  
邮编: 010010  
电话: (0471) 693 8888  
传真: (0471) 628 8269

### 济南

山东省济南市舜耕路28号  
舜耕山庄商务会所5楼  
邮编: 250014  
电话: (0531) 8266 6088  
传真: (0531) 8266 0836

### 济宁

山东省济宁市火炬路19号济宁  
香港大厦361房间  
邮编: 272037  
电话: (0537) 239 6000  
传真: (0537) 235 7000

### 青岛

山东省青岛市香港中路76号  
青岛颐中皇冠假日酒店4楼  
邮编: 266071  
电话: (0532) 8573 5888  
传真: (0532) 8576 9963

### 潍坊

山东省潍坊市四平路31号山东将军  
腾飞大酒店有限公司1507房间  
邮编: 261041  
电话: (0536) 822 1866  
传真: (0536) 826 7599

### 烟台

山东省烟台市南大街9号  
金都大厦16F1606室  
邮编: 264001  
电话: (0535) 212 1880  
传真: (0535) 212 1887

### 淄博

山东省淄博市张店区中心路177号  
淄博饭店7楼  
邮编: 255025  
电话: (0533) 218 7877

### 沈阳

辽宁省沈阳市辽河区北站路59号  
财富中心E座13层  
邮编: 110013  
电话: (024) 8251 8114  
传真: (024) 8251 8597

### 大连

辽宁省大连市高新园七贤岭  
广贤路117号  
邮编: 116001  
电话: (0411) 8369 9760  
传真: (0411) 8360 9468

### 长春

吉林省长春市西安大路569号  
长春香格里拉饭店401房间  
邮编: 130061  
电话: (0431) 8898 1100  
传真: (0431) 8898 1087

### 哈尔滨

黑龙江省哈尔滨市南岗区红军街15号  
奥威斯发展大厦30层A座  
邮编: 150001  
电话: (0451) 5300 9933  
传真: (0451) 5300 9990

## 华东区

### 上海

上海市杨浦区大连路500号  
西门子上海中心A座7楼  
邮编: 200082  
电话: (021) 3889 3889

### 杭州

浙江省杭州市西湖区杭大路15号  
嘉华国际商务中心1505室  
邮编: 310007  
电话: (0571) 8765 2999  
传真: (0571) 8765 2998

### 南京

南京市中山路228号地铁大厦17层  
邮编: 210008  
电话: (025) 8456 0550  
传真: (025) 8451 1612

### 苏州

苏州工业园区苏华路2号  
国际大厦1115~1119室  
邮编: 215021  
电话: (0512) 6288 8191 - 8316  
传真: (0512) 6661 4898

## 华南区

### 广州

广州市天河区天河路208号  
粤海天河城大厦8~10层  
邮编: 510620  
电话: (020) 3718 2888  
传真: (020) 3718 2107

### 福州

福州市五四路136号  
中银大厦21层  
邮编: 350003  
电话: (0591) 8750 0888  
传真: (0591) 8750 0333

### 厦门

厦门市厦禾路189号  
银行中心21层2111-2112室  
邮编: 361003  
电话: (0592) 268 5508  
传真: (0592) 268 5505

### 佛山

佛山市汾江南路38号  
东建大厦19楼K单元  
邮编: 528000  
电话: (0757) 8232 6710  
传真: (0757) 8232 6720

### 东莞

东莞市南城区宏远路1号  
宏远大厦1403-1405室  
邮编: 523087  
电话: (0769) 2240 9881  
传真: (0769) 2242 2575

### 深圳

深圳市华侨城汉唐大厦9楼  
邮编: 518053  
电话: (0755) 2693 5188  
传真: (0755) 2693 4245

### 汕头

汕头市金海湾大酒店1502房  
邮编: 515041  
电话: (0754) 848 1196  
传真: (0754) 848 1195

### 海口

海南省海口市滨海大道69号  
宝华海景大酒店 8 层803房  
邮编: 570105  
电话: (0898) 6678 8038  
传真: (0898) 6678 2118

### 珠海

珠海市景山路193号  
珠海石景山旅游中心229房间  
邮编: 519015  
电话: (0756) 337 0869  
传真: (0756) 332 4473

### 南宁

南宁市金湖路63号  
金源现代城9层935室  
邮编: 530022  
电话: (0771) 552 0700  
传真: (0771) 552 0701

## 华中区

### 武汉

湖北省武汉市汉口江汉区  
建设大道709号建银大厦19楼  
邮编: 430015  
电话: (027) 8548 6688  
传真: (027) 8548 6777

### 郑州

河南省郑州市中原区中原中路220号  
裕达国贸中心写字楼2506房间  
邮编: 450007  
电话: (0371) 6771 9110

### 长沙

湖南省长沙市五一中路68号  
亚大时代写字楼2101、2101-2室  
邮编: 410011  
电话: (0731) 8446 7770

### 合肥

安徽省合肥市濉溪路278号  
财富广场27层2701、2702室  
邮编: 230041  
电话: (0551) 568 1299

### 南昌

江西省南昌市北京西路88号  
江信国际大厦14楼1403/1405室  
邮编: 330046  
电话: (0791) 630 4866

## 西区

### 西安

西安市高新区科技路33号  
高新国际商务中心28楼  
邮编: 710075  
电话: (029) 8831 9898  
传真: (029) 8833 8818

### 兰州

甘肃省兰州市东岗西路589号  
锦江阳光酒店2206室  
邮编: 730000  
电话: (0931) 888 5151  
传真: (0931) 881 0707

### 银川

宁夏回族自治区银川市北京东路123号  
太阳神大酒店A区1507房间  
邮编: 750001  
电话: (0951) 786 9866  
传真: (0951) 786 9867

### 西宁

青海省西宁市新宁路新宁花苑A座  
紫恒国际公寓16楼21613室  
邮编: 810008  
电话: (0971) 550 3390  
传真: (0971) 550 3390

### 乌鲁木齐

新疆乌鲁木齐市五一一路160号  
鸿福大饭店贵宾楼918室  
邮编: 830000  
电话: (0991) 582 1122  
传真: (0991) 581 5387

### 成都

四川省成都市高新区天华二路81号  
天府软件园C6栋1/2楼  
邮编: 610041  
电话: (028) 6238 7339  
传真: (028) 6238 7093

### 重庆

重庆市渝中区邹容路68号  
大都会商厦18层1807 - 1811  
邮编: 400010  
电话: (023) 6382 8919  
传真: (023) 6370 0612

### 贵阳

贵州省贵阳市新华路72号  
富中国际广场 15楼 C区  
邮编: 550002  
电话: (0851) 551 0310  
传真: (0851) 551 3932

### 昆明

云南省昆明市北京路155号  
红塔大厦1204室  
邮编: 650011  
电话: (0871) 315 8080  
传真: (0871) 315 8093

### 绵阳

四川省绵阳市高新区  
火炬广场西街北段89号长虹大酒店四楼  
邮编: 621000  
电话: (0816) 241 0137  
传真: (0816) 241 8950

西门子（中国）有限公司  
基础设施与城市业务领域  
中低压集团

如有变动，恕不事先通知  
订货号：E20001-K7320-C300-V3-5D00  
269-S906224-12123

西门子子公司版权所有

本手册中提供的信息只是对产品的一般说明和特性介绍。文中内容可能与实际应用的情况有所出入，并且可能会随着产品的进一步开发而发生变化。仅当相关合同条款中有明确规定时，西门子方有责任提供文中所述的产品特性。

手册中涉及的所有名称可能是西门子公司或其供应商的商标或产品名称，如果第三方擅自使用，可能会侵犯所有者的权利。