

A tall wooden utility pole stands against a blue sky with scattered white clouds. At the top, a power line runs horizontally, supported by insulators. A Siemens logo is overlaid on a white rectangular box in the upper left. Further down the pole, there are various electrical components: a blue insulator assembly, a black cable, and a white outdoor vacuum circuit breaker. Below these, a solar panel is mounted on the pole, with a small antenna nearby. At the bottom of the pole, a white remote control unit is attached.

SIEMENS

Catalogue
Edition
2019

Fusesaver™

with reclosing functionality

Outdoor vacuum circuit breaker
and Remote Control Unit

[siemens.com/fusesaver](https://www.siemens.com/fusesaver)

Fusesaver™ with
reclosing functionality.
Outdoor vacuum circuit
breaker and Remote
Control Unit.



Rural network challenges 04



Fusesaver™ 05

The Fusesaver™ system	06
Fusesaver™ mounting options	08
Communications Module	08
Siemens Connect software	10
Fusesaver™ protection	12
Fusesaver™ ratings summary	14
Battery performance	15

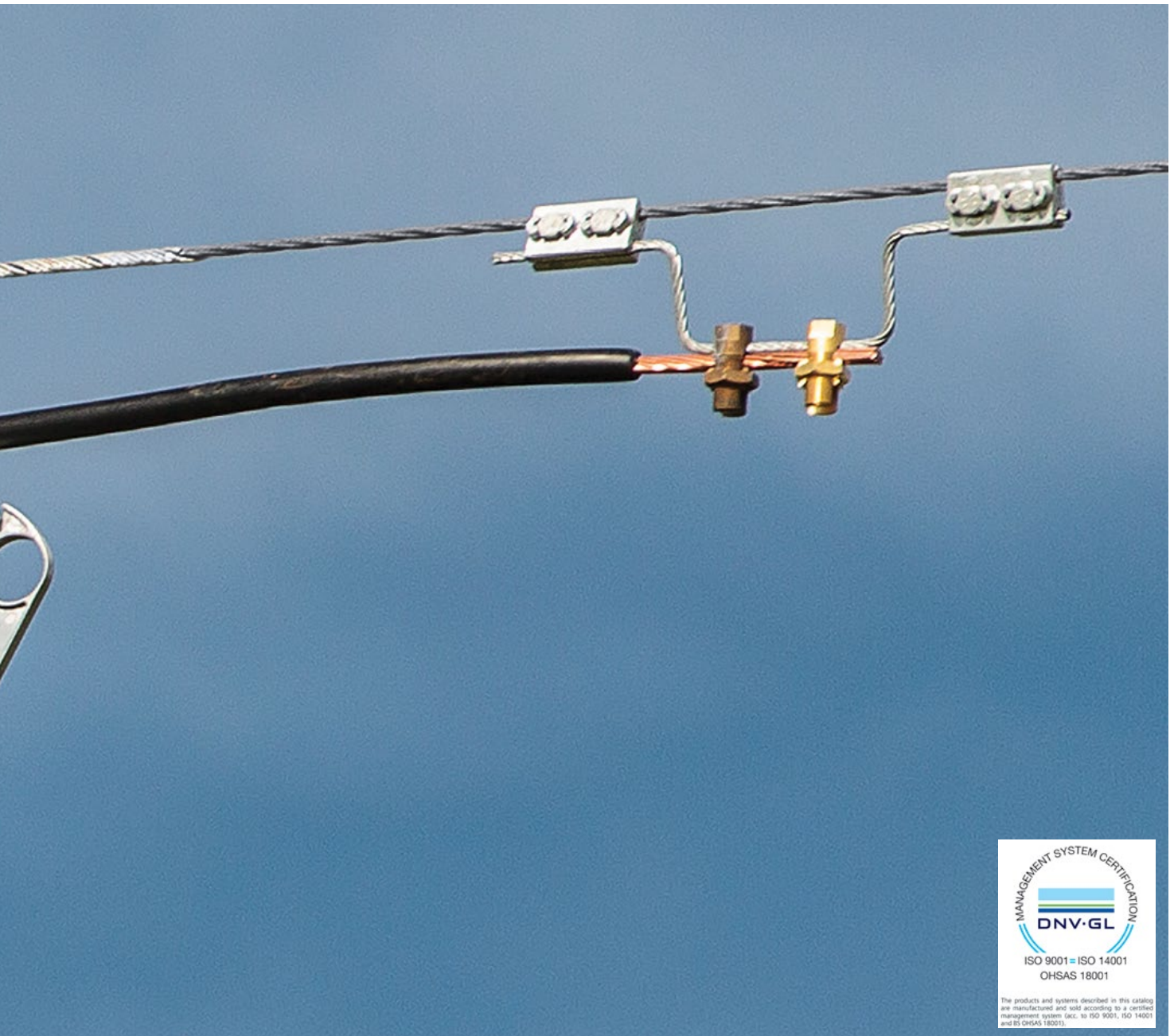

Remote Control Unit 16

RCU principle	16
The RCU system	16
RCU cubicle	17
RCU accessories	18
RCU communications	19



Product selection 20

Order number structure	21
Fusesaver™	22
Remote Control Unit (RCU)	24
Fusesaver Dimensions	25
Remote Control Unit Dimensions	26

Rural network challenges

Since typically 80 percent of a rural network’s faults are transient, 80 percent of its fuses are blown unnecessarily.



In most rural network configurations, the feeder is protected by a circuit-breaker or recloser. Lateral lines (also referred to as T-offs or spur lines) are usually protected by fuses.

As a fuse is unable to distinguish between temporary and permanent faults, it blows on all faults, causing downstream customers to lose power and requiring a line crew to replace the fuse.

In rural networks, it may take hours for the line crew to drive to a site, patrol the line, replace fuses, and reconnect supply. This leads to unnecessary high operating costs for the utility.

Furthermore, downstream users are left without power for extended periods of time potentially resulting in financial penalties to the utility.

Due to the low customer numbers on rural lateral lines, it is often difficult for the utility to find a cost effective solution to this problem... until now!

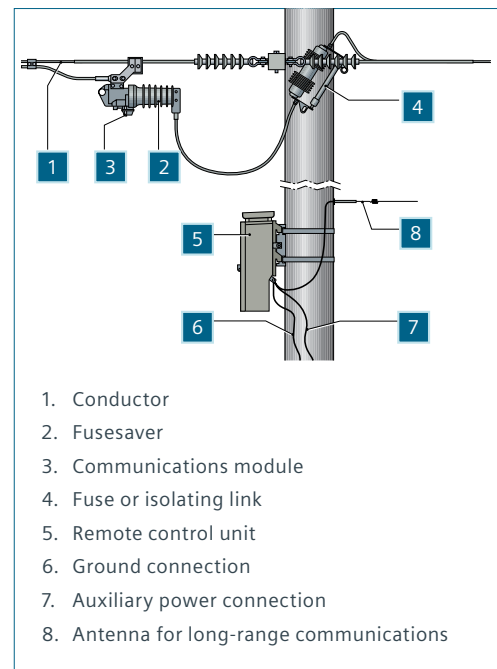
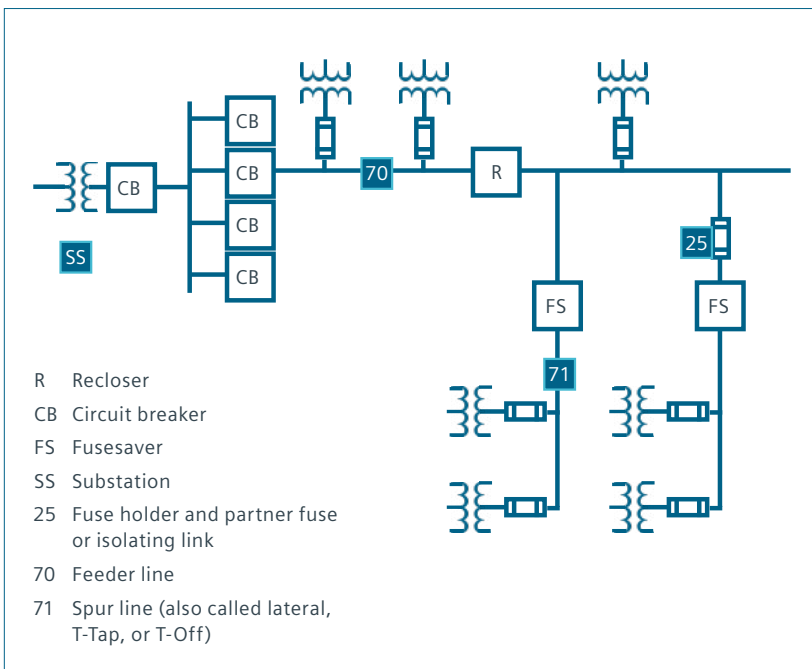

Fusesaver™

The world's fastest medium-voltage outdoor reclosing vacuum circuit breaker.

Fusesaver™ is the most cost-effective solution for optimising reliability while minimising operating costs of rural overhead medium-voltage networks. It is capable of almost completely removing the impacts of temporary faults on lateral lines.

Fusesaver™ is a new class of intelligent, compact and low-cost, single-phase reclosing circuit-breaker.

With on board microprocessor control and wireless connectivity, Fusesaver™ has configurable protection, multi-phase operation functions, on board event history, load profiling and can be integrated into a SCADA system for remote control.

It is an electrically floating device that hangs directly from the medium-voltage line.

It self-powers by harvesting and storing energy from the line current. Fault detection is achieved with a cutting-edge, high-speed protection algorithm that is capable of clearing a fault in as little as a half-cycle making it the fastest medium-voltage circuit breaker in the world.

The Fusesaver™ can be customer configured to either be installed in conjunction with a partner fuse or as a standalone protection device.

Installed in series with the fuse. After tripping on a fault, the Fusesaver™ stays open for a pre-determined time (dead time) to clear a transient fault. Then, the Fusesaver™ closes again reconnecting supply. If the line is still faulted, the fuse now operates to clear the permanent fault. This is the traditional Open-Close (OC) Fusesaver™ approach.

Fusesaver™ (O-1s-C)* with partner fuse

While the fuse protects the lateral line, the Fusesaver™ protects the fuse from transient faults.

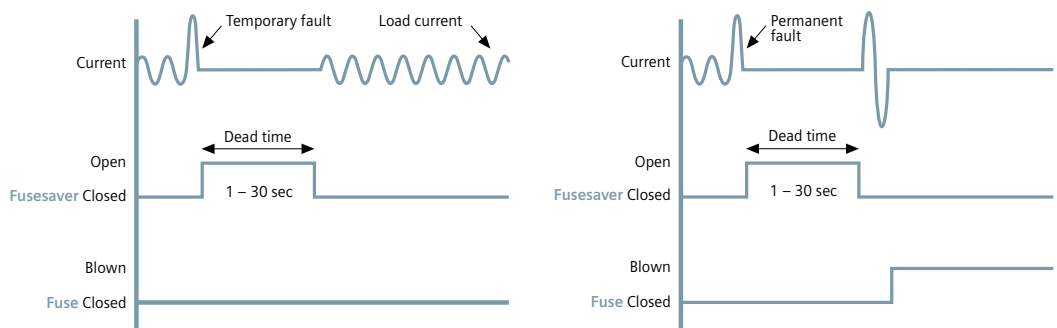

Replace the fuse altogether. When installed in this manner, the Fusesaver™ can perform the same Open-Close functionality as above to clear a transient fault but can also perform a second "Open" operation (O-CO) to clear a permanent fault.

Fusesaver™ (O-2s-C-O)* without partner fuse

The Fusesaver™ O-CO is the ultimate Fusesaver™ as the fuse is not required at all.

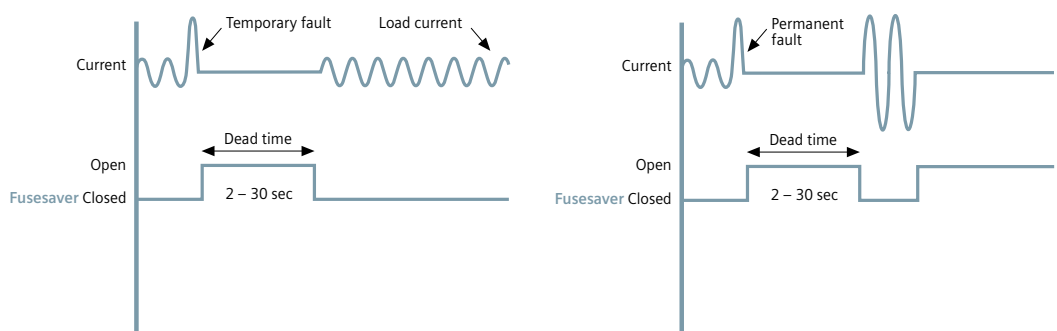

*Highest customer flexibility: One hardware platform, two selectable operating sequences and multiple other configuration file settings.

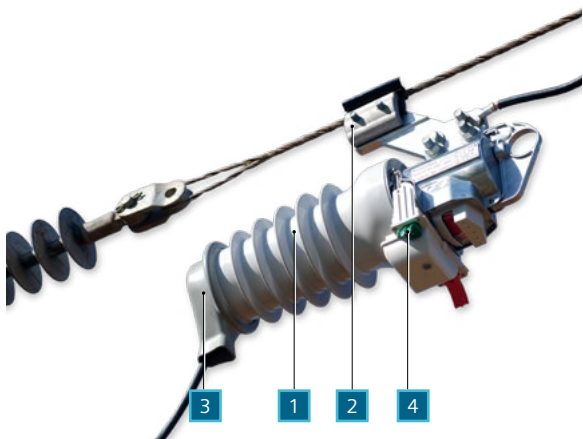

A typical Fusesaver™ application includes the following items for each phase:

1. Fusesaver™
2. Line-clamp assembly
3. Bird guard
4. Communications Module

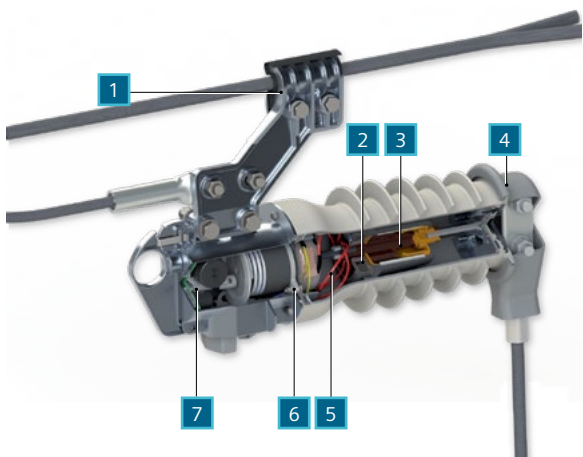

1. Dead end
2. Fault-detection current transformer
3. Vacuum interrupter
4. Bird guard
5. Power current transformer
6. Magnetic actuator
7. Electronic module

SIEMENS	
Type 3AD8423	Year of manuf. 2018
No. NGJ 3AD8/0001000	Ir 200 A
Ur 27 kV 50/60 Hz	I _{ma} 6.3 kA
I _{sc} 6.3 kA, t _k 1 s	M 5 kg
U _{d/Up} 60/125 kV	0 - 2s - CO / 0 - 1s - C
MADE IN AUSTRALIA	According to IEC 62271-100

The Fusesaver™ system

In order to minimise installation and operating costs, the Fusesaver™ was developed as part of an integrated system of tools and accessories. All system components work together, which permits easy installation, fast commissioning, and reliable operation in all conditions.

A typical Fusesaver™ installation includes the following items for each phase:

1. Fusesaver™
2. Line-clamp assembly
3. Bird guard
4. Communications Module.

Configuration of the unit is achieved through a wireless connection to a PC application called Siemens Connect.

Design of the switch unit

The Fusesaver™ is a fully integrated unit consisting of a vacuum interrupter driven by a magnetic actuator. On-board current transformers both power the Fusesaver™ and provide current measurement inputs into the built-in electronics control and protection module.

The external insulation is high-grade silicone rubber and the mechanism housing marine-grade aluminium for long outdoor life.

Self-powering

The Fusesaver™ is capable of self-powering from the very low line currents found on rural overhead networks.

Magnetic actuator

The magnetic actuator is an innovation by Siemens applied to the Fusesaver™ to provide half-cycle interruption capability. The magnetic actuator can detach in less than 2 ms and have the vacuum interrupter contacts fully open within another 4 ms.

The magnetic actuator is directly coupled to the position indicator, which is visible from ground level.

Nameplate

Note: For any request regarding spare parts, subsequent deliveries, etc., the following details are necessary:

- Type designation
- Serial No.
- Year of manufacture.

Vacuum interrupter

The Fusesaver™ relies upon Siemens well-established vacuum interrupter technology. The vacuum interrupter utilised in the Fusesaver™ is a specific innovation by Siemens to facilitate the half-cycle fault interruption capability required to be able to save fuses successfully.

**Position indicator**

The indicator is directly coupled to the magnetic actuator and has red/green colours to indicate close/open status (colours can be reversed by special order).



Fusesaver™ position indicator

External lever

The Fusesaver™ is fitted with an external lever that allows an operator to change the protection and other operational parameters of the Fusesaver™.

For example, when live-line work is performed downstream of the Fusesaver™, the operator can pull the lever down to change the Fusesaver™ protection to a fast curve with single trip to lockout.

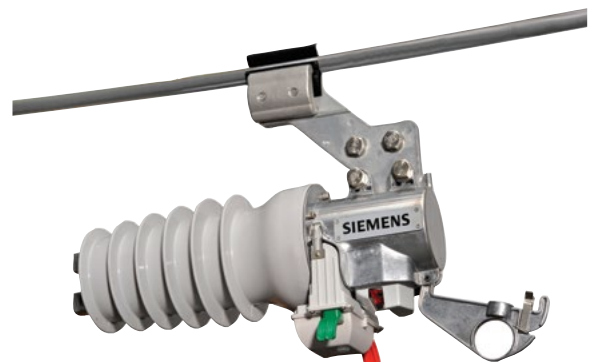

External lever shown in DOWN position

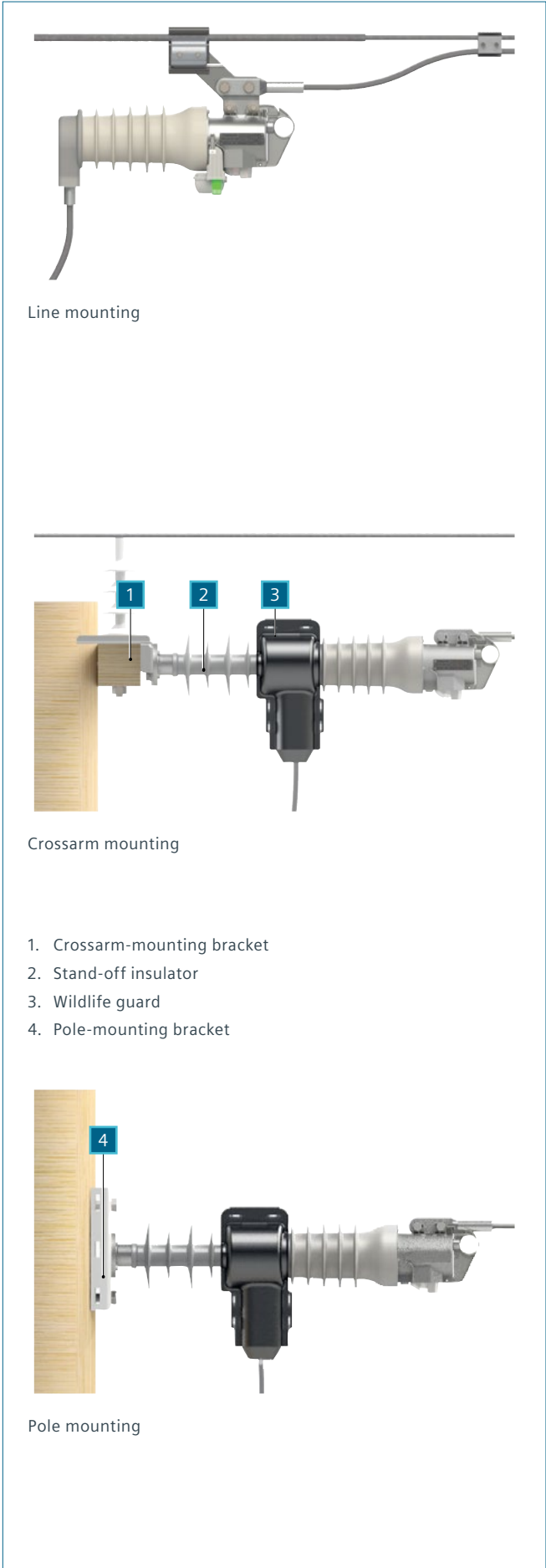

Fusesaver™ mounting options

Fusesaver™ is an electrically floating device so requires no grounding. This product architecture allows for a number of different mounting options. In all cases the Fusesaver™ has been designed to be mounted horizontally.

Line mounting

The preferred method for mounting of the Fusesaver™ is to hang it directly from the line using the line-clamp assembly. The line-clamp assembly connects directly to the dead-end of the conductor and ensures that the Fusesaver™ is hung at its centre of mass. A cable connects the Fusesaver™ terminals to the conductor.

Crossarm or pole mounting

For locations where it is impractical to line mount the Fusesaver™, an alternative is to use a crossarm or the pole. A composite station post insulator with special end brackets is used to support the Fusesaver™.

Line-tension mounting

The Fusesaver™ can be mounted as part of the line construction using the inline tension plate.

Communications Module

The Communications Module plugs into the Fusesaver™ and provides a short-range wireless link between the Fusesavers™ and to other devices. It also has a built-in battery to provide a backup energy source to the Fusesaver™ during periods when there is no line current.

The Communications Module has multiple purposes.

- At time of commissioning to allow the Fusesaver™ to be configured and tested
- During service to allow Fusesaver™ to be manually operated, line data accessed and event logs downloaded
- To enable multi-phase protection functionality
- To enable synchronous ganged manual operation
- To enable the above functions and also connection to the Remote Control Unit (RCU) thereby integrating the Fusesaver™ into the user's SCADA network.

Wireless communications

The Communications Module includes an intelligent, short-range wireless transceiver, which enables encrypted communication using the public 2.4 GHz band.

Battery

The Communications Module includes a battery to provide power to run the Communications Module radio and to manually operate the Fusesaver™ when the line current is off. The Communications Module is available in two models:

1. The classic version with fitted-for-life, primary-cell battery.
2. The rechargeable version with battery cells that can be recharged by the Fusesaver™’s line current. The battery cells can also be replaced by the user through an access panel.

LED and fault-passage indication

The Communications Module has a transparent window on the underside behind which is a high-intensity LED. When illuminated, this LED is visible from the ground in daylight. The LED is used to assist the operator during commissioning and when manually operating the Fusesaver™. In the event of a line fault, the LED flashes for up to seven hours to indicate a fault current has passed through the Fusesaver™.

Tripping and closing

The Communications Module is fitted with external actuators that may be used to trip or close the Fusesaver™. Using the wireless communications between the Fusesaver™, it is also possible to synchronously trip and close Fusesaver™ on adjacent phases.

Attachment tool

An attachment tool is available for each model of Communications Module to allow a user with a live-line stick to insert and remove the Communications Module from ground level.

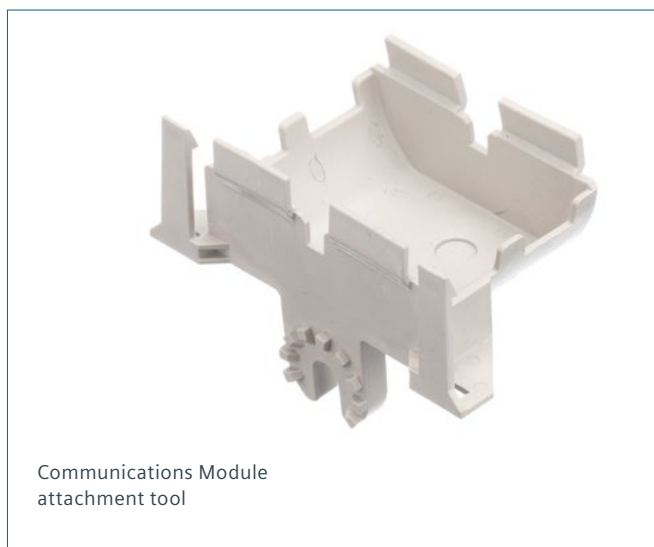



Fusesaver™ plus Communications Module communicates with USB antenna

Siemens Connect software

Communication with the Fusesaver™ circuit breaker is performed using a PC application called Siemens Connect and a USB radio antenna. With these items, a local operator has short-range (approximately 20 m) access to the Fusesaver™ over the encrypted radio link.

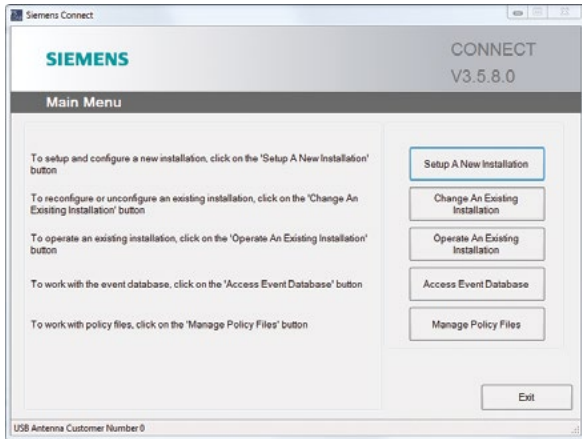

Configuration

The Fusesavers™ are configured wirelessly through the Siemens Connect PC application. All the user needs to do is to identify the Fusesavers™ to be configured together as a site, load the policy file that includes the protection settings defined by the utility and tell the Fusesaver™ the type and rating of its partner fuse. The entire process is completed within a few minutes.

If network requirements change, the Fusesaver™ can be reconfigured with new protection and operational settings while remaining in service.

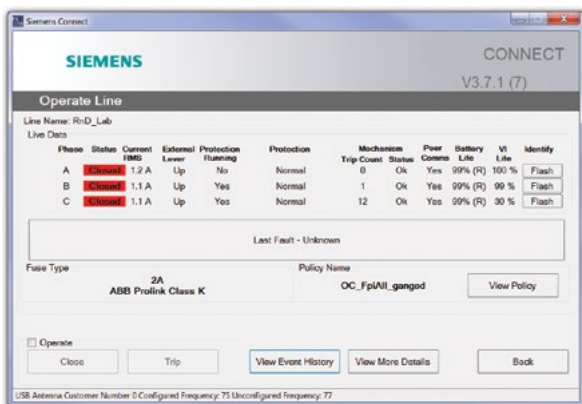

Operation

When on-site, the line crew can access the live data in the Fusesaver™ using the Siemens Connect PC application.

The operators also have the ability to trip and close the Fusesaver™ using controls from the PC.

Event data

Fusesaver™ stores a time-stamped history of the major events in its on-board memory. The event record contains a history of up to 3,000 events including protection operations, fault data, outage durations, and configuration changes.

The event data can be viewed using the Siemens Connect PC application. Data can be filtered and exported as required.

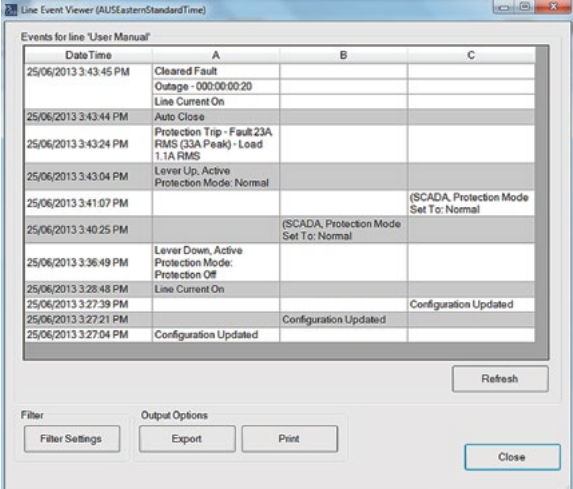

Line Event Viewer (AUEasternStandardTime)

Events for line 'User Manual'

Date/Time	A	B	C
25/06/2013 3:43:45 PM	Cleared Fault Outage - 000:00:00:20 Line Current On		
25/06/2013 3:43:44 PM	Auto Close		
25/06/2013 3:43:24 PM	Protection Trip - Fault 23A RMS (33A Peak) - Load 1.1A RMS		
25/06/2013 3:43:04 PM	Lever Up, Active Protection Mode: Normal		(SCADA, Protection Mode Set To: Normal)
25/06/2013 3:41:07 PM		(SCADA, Protection Mode Set To: Normal)	
25/06/2013 3:40:25 PM	Lever Down, Active Protection Mode: Protection Off		
25/06/2013 3:28:48 PM	Line Current On		
25/06/2013 3:27:39 PM			Configuration Updated
25/06/2013 3:27:21 PM		Configuration Updated	Configuration Updated
25/06/2013 3:27:04 PM	Configuration Updated		

Filter: Output Options:

Load-profile data

The Fusesaver™ can collect data on the current flowing in each phase of an installation. The Fusesaver™ can report the following data for each 24 hour period:

- The minimum current (with time-stamp)
- The maximum peak current (with time-stamp)
- The average daily current.



Reliability data

The line reliability analysis tool allows the user to generate reliability performance data for a particular line.

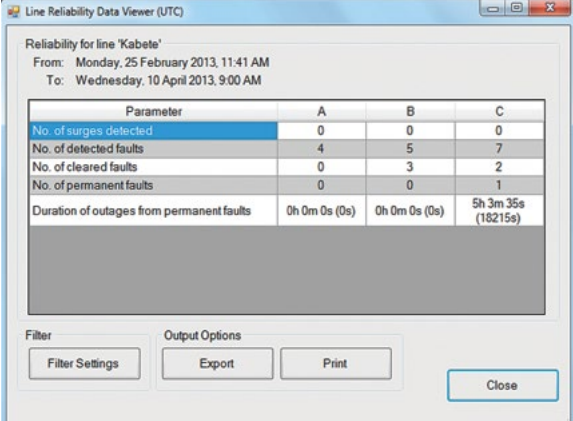

Line Reliability Data Viewer (UTC)

Reliability for line 'Kabete'

From: Monday, 25 February 2013, 11:41 AM
To: Wednesday, 10 April 2013, 9:00 AM

Parameter	A	B	C
No. of surges detected	0	0	0
No. of detected faults	4	5	7
No. of cleared faults	0	3	2
No. of permanent faults	0	0	1
Duration of outages from permanent faults	0h 0m 0s (0s)	0h 0m 0s (0s)	5h 3m 35s (18215s)

Filter: Output Options:

Fusesaver™ protection

Fusesaver™ with partner fuse – time-current curve
(a FAST protection curve can be added as shown in the lower figure)

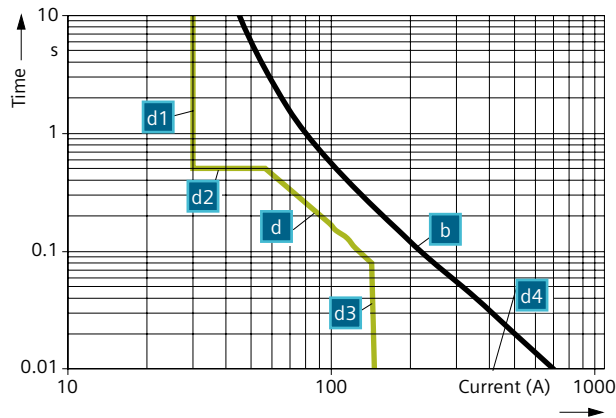

- b K-type 15 A fuse
- d Fusesaver™ set to coordinate with a 15 A K-type fuse
- d1 Minimum trip-current multiplier (x2)
- d2 Maximum fault time (0.5 sec)
- d3 Instantaneous multiplier (x10)
- d4 Minimum fault time (OFF)

Fuse replacement protection – time-current curve

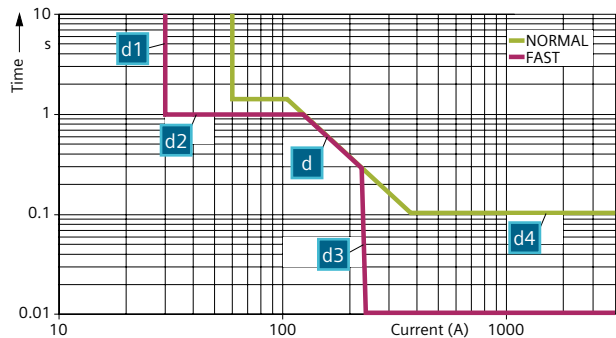

- d Fusesaver™ set to coordinate with a 30 A K-type fuse
- d1 Minimum trip-current multiplier (x2/x1)
- d2 Maximum fault time (1.5 sec/1 sec)
- d3 Instantaneous multiplier (x20/x8)
- d4 Minimum fault time (0.1 sec/OFF)

Time-current curve

Fault detection is achieved with a cutting-edge, high-speed protection algorithm that is capable of detecting faults within 2 ms. On the first trip, the Fusesaver™ can clear the fault in the first half-cycle after contact part when required.

The default Fusesaver™ protection algorithm uses an inverse protection curve that is based upon an i^2t value.

The Fusesaver™ can store two protection curves, a NORMAL and a FAST protection curve. The inverse part of the curve (d) is defined by the i^2t of the fuse type the Fusesaver™ is protecting or replacing and is common to both curves. Additional configuration items required for each curve are the pick-up level (d1), the maximum time element (d2), the instantaneous multiplier (d3), and the minimum time element (d4).

Inrush restraint

On line re-energisation after any outage, short-term inrush currents associated with motors starting and transformer core-magnetisation occur. The Fusesaver™ can be configured to apply an inrush pick-up multiplier to temporarily increase the fault pick-up threshold to avoid unnecessary tripping on inrush currents.

Cold-load pickup

Due to the loss of load diversity during an extended outage, the current on restoration can be higher than normal until diversity returns. The Fusesaver™ can be configured to apply a cold-load multiplier to increase the fault temporarily pick-up threshold for a configurable period to avoid unnecessary tripping on higher than normal load currents.

Dead-time setting

The dead time is the period after the Fusesaver™ has tripped on a fault and before it closes. In general, the longer the dead time the greater the chance that the operation of the Fusesaver clears a transient fault. Dead time is configurable in the range of 1-30 s.

Pseudo three-phase trip and reclose

When all the Fusesavers™ on a line at a single location are fitted with communications modules, it is possible to configure them so that if one detects a fault and trips, the other two phases trip shortly afterwards. All three phases then reclose simultaneously after the dead time of the Fusesaver™ that tripped first. This feature may be used to block backfeed current on a delta load circuit.

Three-phase lockout protection

When all the Fusesavers™ on a line at a single location are fitted with communications modules, it is possible to configure them so that if any one of them does a trip to lockout then all three phases will trip to lockout after a short delay. Fusesaver™ may be configured with both pseudo three-phase trip and three-phase lockout enabled.

Protection modes

The operation of the Fusesaver™ protection can be altered by changing the protection mode. The modes available depend upon whether the Fusesaver™ is used with a partner fuse or as a fuse replacement. Further, the Fusesaver™ stores a mode selection that is applicable if the external lever is in the UP or DOWN position to allow users to adjust to different operational requirements when a live line crew is working downstream of a Fusesaver™. The protection modes are:

Mode	OC	OCO	Functionality
Protection OFF	Yes	Yes	The Fusesaver™ does not trip on a fault.
Normal	Yes	No	The Fusesaver™ trips based on the NORMAL curve settings and recloses after the dead time.
Fast	Yes	No	The Fusesaver™ trips based on the FAST curve settings and recloses after the dead time.
Normal-normal	No	Yes	The Fusesaver™ trips based on the NORMAL curve settings. The Fusesaver™ recloses after the dead time. If the fault is still present, the Fusesaver™ trips a second time based on the NORMAL curve settings and then stays in the open state.
Normal-fast	No	Yes	The Fusesaver™ trips based on the NORMAL curve settings. The Fusesaver™ recloses after the dead time. If the fault is still present, the Fusesaver™ trips a second time based on the FAST curve settings and then stays in the open state.
Fast-normal	No	Yes	The Fusesaver™ trips based on the FAST curve settings. The Fusesaver™ recloses after the dead time. If the fault is still present, the Fusesaver™ trips a second time based on the NORMAL curve settings and then stays in the open state.
Fast-fast	No	Yes	The Fusesaver™ trips based on the FAST curve settings. The Fusesaver™ recloses after the dead time. If the fault is still present, the Fusesaver™ trips a second time based on the FAST curve settings and then stays in the open state.
Normal-single	Yes	Yes	The Fusesaver™ trips based on the NORMAL curve settings. The Fusesaver™ does not reclose and stays in the open state.
Fast-single	Yes	Yes	The Fusesaver™ trips based upon the FAST curve settings. The Fusesaver™ does not reclose and stays in the open state.

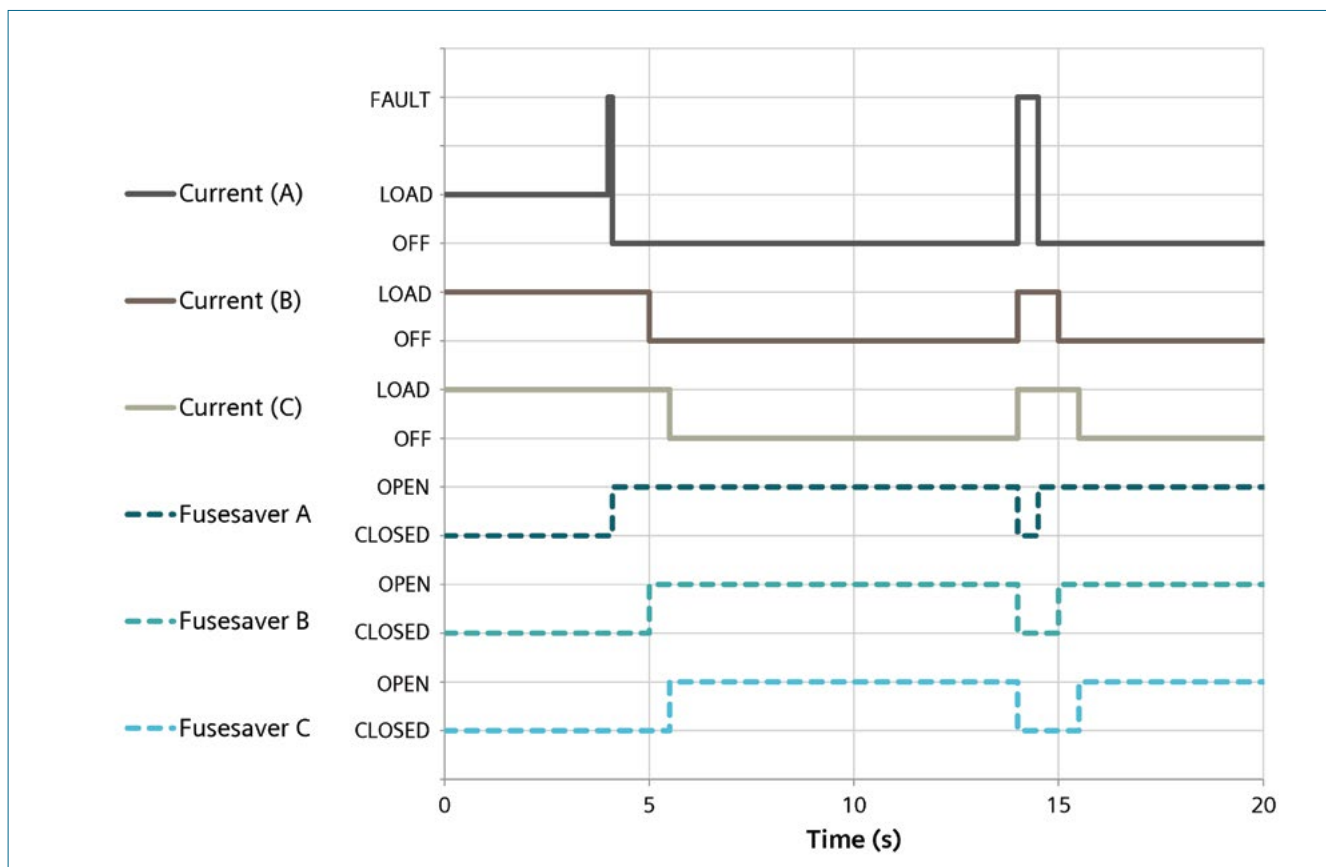

Pseudo three-phase trip and reclose and three-phase lockout protection

Fusesaver™ ratings summary

Standards

The Fusesaver™ conforms to the relevant sections of IEC 62271-100.

Fusesaver™ is available in a number of models determined by load current, fault current, and self-powering from line-current capability as follows:

Model type	Unit	Low range	Standard range	High range
Minimum line current for operation and battery charging	A	0.15	0.5	1.0
Rated current I_r	A	40	100	200
Rated short-circuit breaking current I_{sc}	kA	1.5	4	6.3
Rated short-circuit making current I_{peak}	kA	3.75	10.4	16.4
Rated short-time current I_k	kA	1.5	4	6.3
Rated short-time current duration t_k	s	0.2	0.2	0.5
Fault-break operations at 100%	No.	300	70	30
Rated operating sequence			O – 1s – C/O – 2s – CO	
Rated clearing time (1st O/2nd O in sequence)			<20ms/<60ms	
Opening and closing times			<20ms	
Rated line-changing current	A	20	20	20
Mechanical operations	No.	2,000	2,000	2,000
IP rating		67	67	67

All Fusesaver™ models are each available with the following voltage rating options:

Rated voltage	kV	15.5	27
Rated lightning-impulse withstand voltage U_p	A	110	125
Rated power-frequency withstand voltage U_d (60 s)	A	50	60

Altitude correction factor

The dielectric strength of air insulation decreases with increasing altitude due to low air density. The rated withstand voltage values specified in the above apply to a site altitude of 1,000 m above sea level.

For altitudes above 1,000 m, the insulation level must be corrected according to IEC 62271-1. The correction applies to the rated power-frequency withstand voltage and the rated impulse-withstand voltage.

To select the devices, the following applies:

$$U \geq U_o \times K_a$$

U = Rated withstand voltage at reference atmosphere

U_o = Rated withstand voltage requested for place of installation

K_a = Altitude correction factor from the diagram.

Ambient conditions

The Fusesaver™ is suitable for use in outdoor environments with ambient temperatures in the range of -40°C to $+50^\circ\text{C}$ and relative humidity in the range of zero percent up to 100 percent.

Service environment	Rating
Humidity	0 to 100%
Maximum altitude	4,000 m

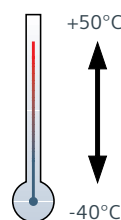

Altitude correction factor

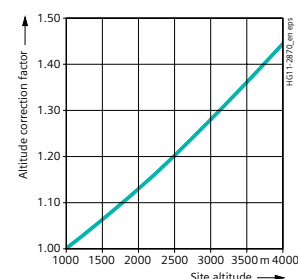

Battery performance

Battery capacity

The Rechargeable Communications Module (RCM) is fitted with two Li-ion battery cells of the 18650 size and capacity of 2,000 mAh.

A new RCM with fully charged batteries at standard temperature and pressure is capable of providing back-up power to the Fusesaver with inadequate line current as follows:

Battery use type	Performance specification
Fusesaver hold-up time	> 10 days, or
Number of trip/ close operations	> 300 operations

The battery capacity is reduced at low temperatures as per the following chart. For expected performance at low temperature multiply the percentage from the chart by the expected hold-up time or number of trip/close operations in the above table.

As the battery cells age and near end-of-life, the available capacity reduces and the rated performance may not be achieved.

Recharging

When the battery in the unit has been used, the time taken to recharge the consumed energy is inversely proportional to the available line current. The time to replenish the charge lost in providing 24 hours of hold-up of the Fusesaver is shown in the figure.

Electrical life

The electrical life of the Fusesaver is limited to the fault interruption capacity of the vacuum interrupter. The electronic controller tracks the number and magnitude of interruptions and estimates when the vacuum interrupter is worn out.

For example, the vacuum interrupter would be worn out after completing 1,000 load-current interruptions at 1,000 A using 50 percent of the available life and 35 fault-current interruptions at 4,000 A using the other 50 percent of life.

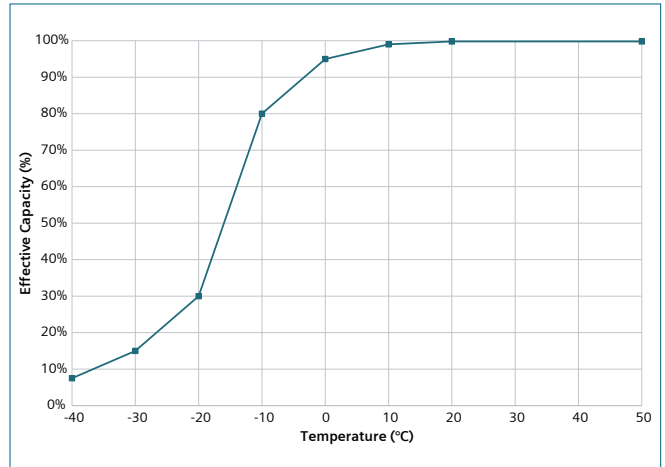

Temperature effects on battery capacity

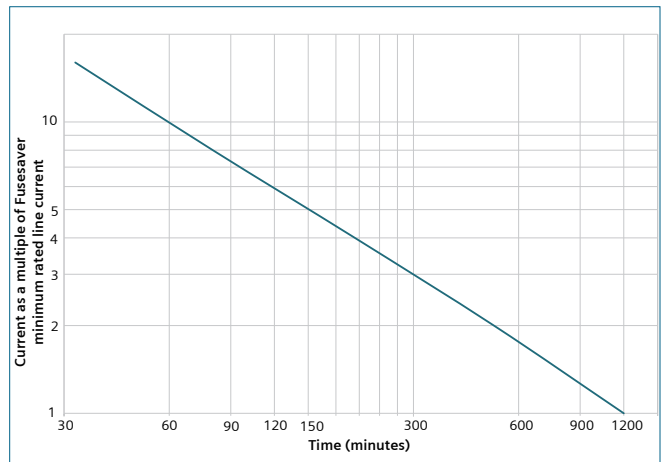

Battery recharge time (after 24 hour outage)

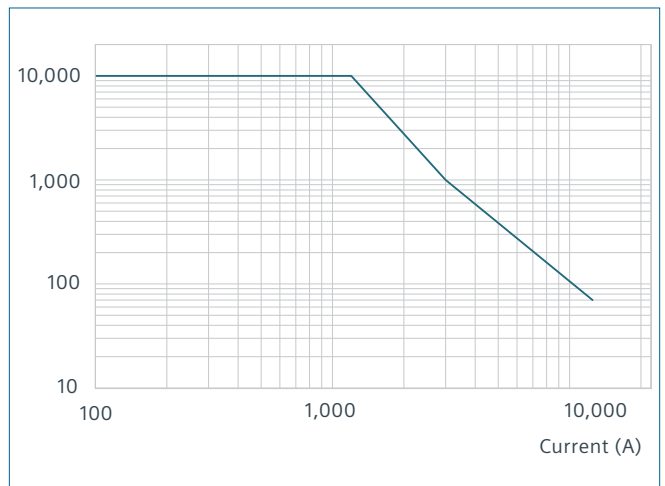

Vacuum interrupter electrical life

Remote Control Unit



A typical Fusesaver™ and RCU installation includes:

1. Fusesavers™ with communications modules
2. Remote Control Unit
3. Solar panel

The Remote Control Unit (RCU) is an optional addition to the Fusesaver™ system used to connect the Fusesaver™ to a utility's SCADA system. The RCU is a pole-mounted enclosure containing a microprocessor, a short-range (approximately 20 m) radio used to communicate with the Fusesaver™. The utility fits a long-range radio (or modem) to communicate with the SCADA centre.

RCU principle

Fusesavers™ are installed on each of the phases of the power line and are organised to work as a set to control that line. One, two, or three Fusesavers™ can be organised in this way for a single-phase, two-phase or three-phase line.

The RCU acts as an interface between a set of Fusesavers™ on the power line and a utility SCADA system. To do this, the RCU uses its configuration to find and access installed and running Fusesavers™. It communicates with the Fusesavers™ using its built-in short-range radio.

In operation, the RCU acquires data from the Fusesavers™ and saves it in its database. Data is transmitted to the utility SCADA system master station over a long-range radio (or modem) using the DNP 3 protocol. The long-range radio (provided by utility) is mounted in the radio tray by the utility and is powered by the RCU. Data in the RCU database includes information about the Fusesavers™ and the RCU itself. Usually, a subset of this data is mapped into the protocol used by the SCADA system.

The RCU system

To minimise installation and operating costs, the Siemens RCU was developed as part of an integrated system of tools and accessories. All system components work together, which permits easy installation, fast commissioning, and reliable operation in all conditions.

A typical Fusesaver™ and RCU installation includes the following items for each phase:

1. Fusesavers™ with communication modules installed permanently
2. RCU
3. Power supply for RCU.

Configuration of the RCU is achieved through a wireless connection to a PC application called RCU Connect.

RCU cubicle

The RCU enclosure is mounted to the pole using the pole-mounting bracket and is manufactured from powder-coated stainless steel for long service life. Material options are available at time of ordering including 304 (standard) and 316 grade stainless steel.

The RCU enclosure has a handle with an internal three-point locking mechanism. An external padlock can be fitted to restrict access.

On the top of the RCU enclosure is a high-grade, UV-stabilised plastic shade hood. This shade hood is to reduce solar heating and to provide an aperture for the short-range radio.

At the rear of the RCU enclosure, there is a ground stud and a number of openings fitted with cable glands to allow external wiring to access the internals of the RCU.

Electronics housing

The electronics housing contains the microprocessor, battery, power connection terminals, data connection points, and the user interface for the RCU. The RCU has a simple user interface for operations and maintenance purposes. The RCU front panel has a number of LED indicators. The LEDs are normally off (to reduce power consumption) and turn on automatically while the door is open as controlled by the position of the door switch.

The electronics housing also holds the 12 V, 7.2 Ah lead-acid battery. The electronics housing is normally powered by a selectable 115/230 Vac low-voltage supply.

Radio tray

The radio tray is available for the installation of the utility-specific radio, modem, or other means to connect to the utility's SCADA system.

The radio tray hinges down and allows access to the radio behind. When in the hinged up position, the tray provides a degree of protection from driving rain.



RCU accessories

Operator panel

The Fusesaver™ operator control panel is an optional accessory mounted on the radio tray and plugs into the RCU’s electronics compartment. The operator control panel allows a local user to trip and close the Fusesavers™ or to change the active protection mode in the Fusesavers™. It also provides additional status information.

There are two operator panels available, one panel for use when Fusesaver™ is configured in OC mode (with a partner fuse) and another for when Fusesaver™ is configured in the O-CO mode (without a partner fuse). As the O-CO mode has protection modes and features different from those for OC mode, the associated panel buttons are different. Even though Fusesaver™ is capable of being used in either OC or O-CO mode, the correct panel must be selected for the mode that will be commissioned.

Low-temperature option

The low-temperature RCU includes a heater mounted behind the radio tray. It has a positive temperature coefficient element which acts as a thermostatic heater keeping the battery and electronic compartment above -15°C for ambient temperatures as low as -30°C.

Solar panel

In environments where good sunlight is available all year, it is possible to power the RCU using a solar power kit option.

This includes the solar panel, mounting bracket, and cable. Solar powering of the RCU is also dependent upon power consumption of the utility’s radio or modem being less than 100 mW on average.

The solar panel is connected into the terminal compartment to a dedicated set of terminals as an alternative to the mains supply.

Solar ratings	Value
Power ratings	65 W
Nominal voltage	18 V
Cell type	Polycrystalline

Voltage transformer

Where low-voltage mains is not available and solar powering is not practical, the RCU should be powered by a voltage transformer connected to the medium-voltage line on which the Fusesaver™ is installed.



RCU communications

Communications interface

To communicate with the SCADA system master station, a long-haul radio or modem is required. The RCU electronics provide a serial, asynchronous data interface (RS232) and an Ethernet port (RJ45) for this purpose.

A purpose-built cable connects the radio/modem to the RCU interface. The design and construction of this cable may be carried out by the customer or as a value-added service provided by Siemens.

Communications protocol

The RCU supports DNP 3.0 over both serial link and IP protocol. The RCU has over 200 digital points and more than 40 analogue points providing status information on the Fusesavers™ and RCU. The RCU can also receive a wide variety of controls from the SCADA master.

RCU configuration

The RCU is configured wirelessly over the short-range radio using the RCU Connect PC application.

Standards

The design and testing of the RCU are according to the relevant parts of IEC 60950-1: 2005 Information technology equipment – Safety.

Ambient conditions

The RCU is suitable for use in outdoor environments with ambient temperatures in the range of -30°C to $+45^{\circ}\text{C}$ and relative humidity in the range of five percent to 95 percent. For temperatures below -15°C , the low-temperature version is required.

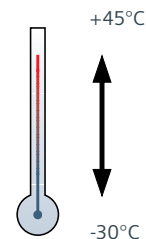
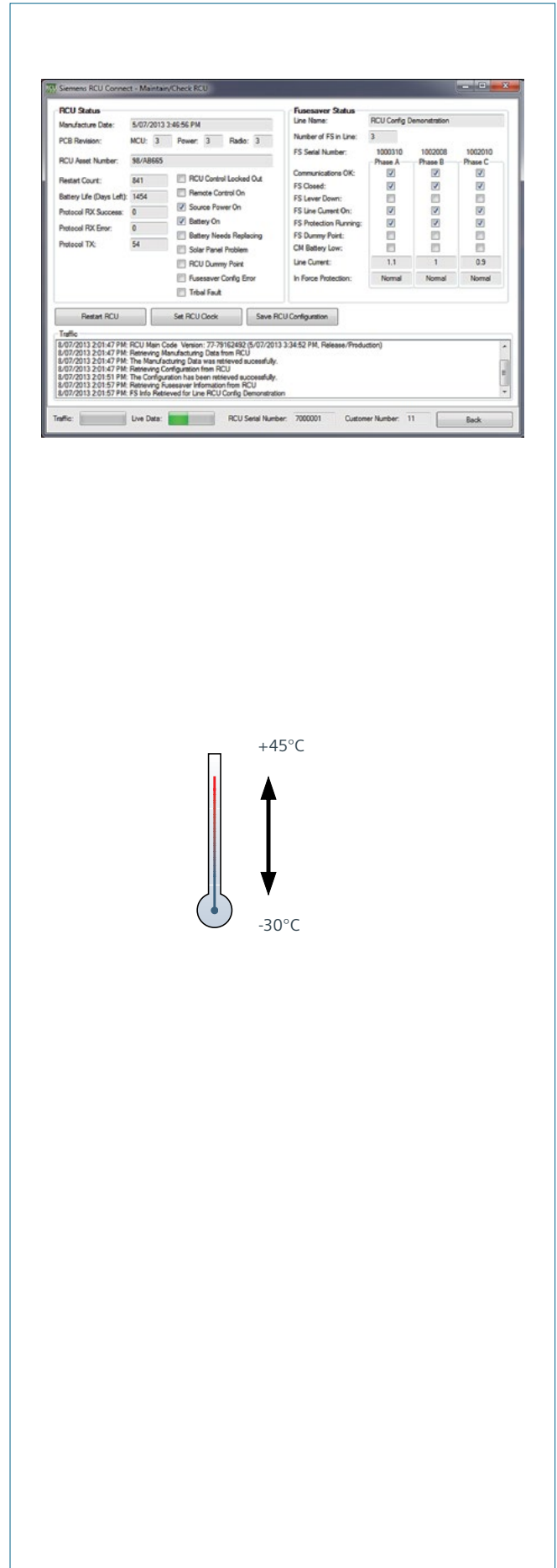

Product selection

Photos and part numbers information



Remote Control Unit



Pole-mount bracket assembly



Wildlife guard

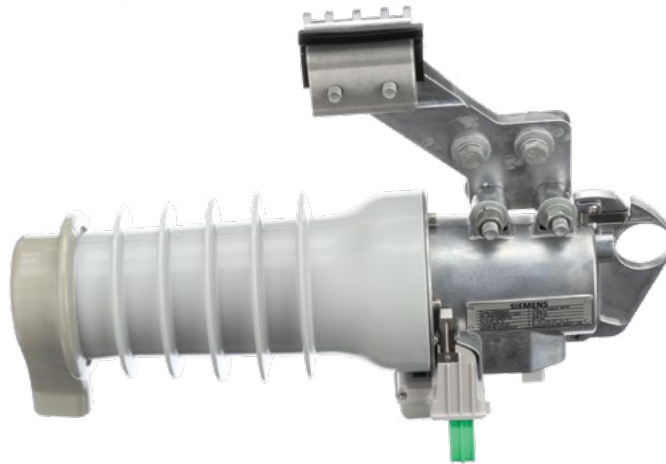

Fusesaver™ with Communications Module, line clamp, and bird guard



PC communications kit



Communications Module

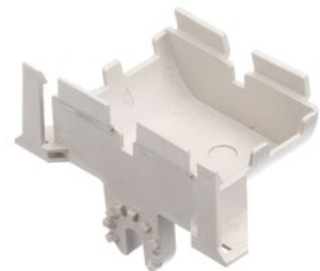

Communications attachment tool

Order number structure

The Siemens Fusesaver order number either configures a Siemens Fusesaver or a Remote Control Unit. The relevant data make up the 16-digit order number. The primary part covers the main electrical data of the Fusesaver or specifies an RCU. The secondary part covers the mounting assembly, communication options and others.

Order codes

Individual equipment versions, marked with **9** or **Z** in the 8th to 16th position, are explained more in detail by a 3-digit order code. Several order codes can be added to the order number in succession and in any sequence.

Special versions

In case of special versions, “-Z” is added to the order number and a descriptive order code follows. If several special versions are required, the suffix “-Z” is listed only once.

If a requested special version is not in the catalogue and can therefore not be ordered via order code, it has to be identified with **Y 9 9** after consultation. The agreement hereto is made between your responsible sales partner and the order processing department.

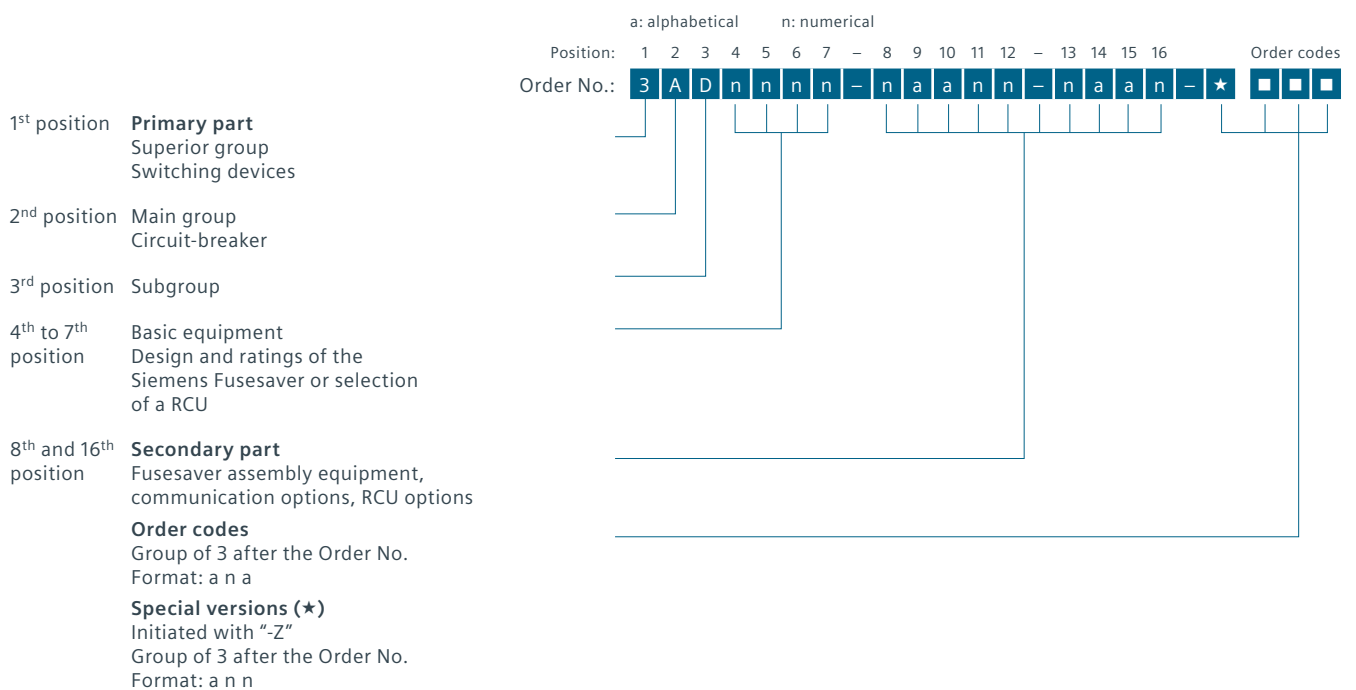

Configuration example

Here you can fill in the order number you have determined for your Fusesaver and RCU.

Example Order No.:

3	A	D	■	■	■	■	-	■	■	■	■	■	■	-	■	■	■	■	■	■	■	■	■
---	---	---	---	---	---	---	---	---	---	---	---	---	---	---	---	---	---	---	---	---	---	---	---

Fusesaver™

Configuration					Position:	1	2	3	4	5	6	7	8	9	10	11	12	13	14	15	16	Order codes				
Rated voltage U_r kV	Rated lightning impulse withstand voltage U_p kV	Rated short-duration power-frequency withstand voltage U_d kV	Rated short-circuit of breaking current I_{sc} kA	Rated normal current I_r A	Order No.:	3	A	D	8	●	●	●	-	●	●	●	●	-	●	●	●	●	●			
15.5	110	50	1.5	40		3	A	D	8	2	3	4			A	0	0		0	A	A					
			4	100		3	A	D	8	2	2	2			A	0	0		0	A	A					
			6.3	200		3	A	D	8	2	4	3			A	0	0		0	A	A					
27	125	60	1.5	40		3	A	D	8	4	3	4			A	0	0		0	A	A					
			4	100		3	A	D	8	4	2	2			A	0	0		0	A	A					
			6.3	200		3	A	D	8	4	4	3			A	0	0		0	A	A					
Fusesaver™ Mounting Assembly																										
No Fusesaver™ Clamping/Mounting Assembly														0												
Line Clamping Assembly incl. Bird Guard													1													
Pole Mounting Assembly incl. Wildlife Guard													2													
Cross-arm Mounting Assembly incl. Wildlife Guard													3													
Pole Mounting Assembly (304 grade s/s) incl. Wildlife Guard													5													
Cross-arm Mounting Assembly (304 grade s/s) incl. Wildlife Guard													6													
Underhung cross-arm mount assembly (304 grade s/s)													7													
Communications Module for Fusesaver™																										
With Communications Module (Primary cell)													B													
Without Communications Module													C													
With Communications Module (Rechargeable)													E													
Language of Operation Manual, Nameplate																										
English																						1				
Other languages on request (increased delivery time)																						9		R	1	Y
Position indicator with interchanged colours "Green: CLOSED, Red: OPEN"																								T	0	7

Fusesaver™ configuration example

1 x Fusesaver™ (27 kV, 4 kA, 100 A), 1 x line clamping assembly incl. bird guard, 1 x Communications Module

3 A D 8 4 2 2 - 1 B A 0 0 - 0 A A 1

Fusesaver™

	Position:	1	2	3	4	5	6	7	8	9	10	11	12	-	13	14	15	16	Order codes					
Fusesaver™ Accessories/Spare Parts	Order No.:	3	A	X	•	•	-	•	•	•	•								-	★	•	•	•	
Communication Accessories																								
Fusesaver™ Communications Module (Primary cell)		3	A	X	1	3	5	0	-	1	A													
Fusesaver™ Communications Module Attachment Tool		3	A	X	1	3	5	0	-	1	B													
Fusesaver™ PC Communications Kit		3	A	X	1	3	5	0	-	1	C													
Fusesaver™ Communications Module Carry Case Kit		3	A	X	1	3	5	0	-	1	D													
Fusesaver™ Communications Module (Rechargeable)		3	A	X	1	3	5	0	-	1	E													
Fusesaver™ Communications Module Attachment Tool (Rechargeable)		3	A	X	1	3	5	0	-	1	G													
Fusesaver™ Communications Module (Rechargeable) – excluding batteries		3	A	X	1	3	5	0	-	1	H													
Molicec Battery Cell (Qty 1)		3	A	X	1	3	5	0	-	1	J													
Mounting Accessories																								
Fusesaver™ Bird Guard		3	A	X	1	3	5	0	-	2	A													
Fusesaver™ Cross-arm Bracket Fish Plate Kit		3	A	X	1	3	5	0	-	2	C													
Fusesaver™ Wildlife Guard (1 piece) includes 6 clips		3	A	X	1	3	5	0	-	2	D													
Fusesaver™ wildlife guard clip (1 piece)		3	A	X	1	3	5	0	-	2	E													
Fusesaver™ Cross-arm Bracket Fish Plate Kit (304 grade s/s)		3	A	X	1	3	5	0	-	2	F													
Fusesaver™ Cross-arm Bracket Fish Plate Kit (316 grade s/s)		3	A	X	1	3	5	0	-	2	G													
Fusesaver™ Line Clamping Assembly		3	A	X	1	3	5	0	-	3	A													
Fusesaver™ Pole Mounting Assembly		3	A	X	1	3	5	0	-	3	B													
Fusesaver™ Cross-arm Mounting Assembly		3	A	X	1	3	5	0	-	3	F													
Fusesaver™ Bracket to composite insulator		3	A	X	1	3	5	0	-	3	K													
Fusesaver™ Pole Mounting Assembly (304 grade s/s)		3	A	X	1	3	5	0	-	3	L													
Fusesaver™ Cross-arm Mounting Assembly (304 grade s/s)		3	A	X	1	3	5	0	-	3	N													
Sandwich plate kit for cross-arm mounting		3	A	X	1	3	5	0	-	3	P													
Fusesaver™ Pole Mounting Assembly (316 grade s/s)		3	A	X	1	3	5	0	-	3	R													
Fusesaver™ Cross-arm Mounting Assembly (316 grade s/s)		3	A	X	1	3	5	0	-	3	T													
Fusesaver™ Pole Mounting Assembly 170kV		3	A	X	1	3	5	0	-	3	V													
Underhung cross-arm mount assembly (304 grade s/s)		3	A	X	1	3	5	0	-	3	W													
Demonstration Kits																								
Demo Kit (27kV/1,5kA/40A Fusesaver)		3	A	X	1	3	5	0	-	4	D													
Demo Kit (27kV/4kA/100A Fusesaver)		3	A	X	1	3	5	0	-	4	E													
Current Injection Set		3	A	X	1	3	5	0	-	4	F													

Remote Control Unit (RCU)

	Position:	1	2	3	4	5	6	7	8	9	10	11	12	13	14	15	16	Order codes					
Configuration	Order No.:	3	A	D	8	•	•	•	-	•	•	•	•	-	•	•	•	-	★	•	•	•	
RCU Battery	7,2 Ah Lead acid																						
RCU Enclosure	316 stainless powdercoated																						
	304 stainless powdercoated (standard)																						
RCU Mounting Assembly	No RCU Mounting Assembly																						
	Standard Pole Mounting Assembly																						
	Side Mounting Assembly																						
	Standard Pole Mounting Assembly (304 grade s/s)																						
	Standard Pole Mounting Assembly (316 grade s/s)																						
RCU Protocols	DNP3																						
RCU Isolator and Heater	None																						
	External Isolated Mains Input																						
	External Isolated Mains Input and Heater																						
Operator Panel	None																						
	RCU Operator Panel – Fusesaver™ OC (Modes)																						
	RCU Operator Panel – Fusesaver™ OCO (Modes)																						
Language of Operation Manual, Nameplate	English																						
	Other languages on request (increased delivery time)																						
	See above at 16th position																						

RCU configuration example

3 A D 8 8 0 0 - 0 A B 3 1 - 1 A A 1

RCU battery type: 7.2 Ah lead acid, RCU enclosure: 304 stainless steel powder-coated, standard pole mounting assembly, RCU protocol: DNP 3.0, without RCU isolator and heater, without operator panel

Remote Control Unit (RCU)

	Position:	1	2	3	4	5	6	7	8	9	10	11	12	13	14	15	16	Order codes					
Accessories/Spare Parts	Order No.:	•	•	•	•	•	-	•	•	•	•	•	•	•	•	•	-	★	•	•	•		
RCU battery 7,2 Ah Lead acid		3	A	X	1	3	5	0	6	A													
Solar panel kit 65W		3	A	X	1	3	5	0	6	B													
VT Mounting Kit (excluding VT)		3	A	X	1	3	5	0	6	K													
RCU Electronic Enclosure (excluding battery)		3	A	X	1	3	5	0	6	L													
RCU Power cable		3	A	X	1	3	5	0	6	M													
Serial Cable RS232 + Power		3	A	X	1	3	5	0	6	P													
RCU Side Mounting Assembly		3	A	X	1	3	5	0	7	A													
RCU Standard Pole Mounting Assembly		3	A	X	1	3	5	0	7	B													
RCU Standard Pole Mounting Assembly (304 grade s/s)		3	A	X	1	3	5	0	7	C													
RCU Standard Pole Mounting Assembly (316 grade s/s)		3	A	X	1	3	5	0	7	D													
RCU Operator Panel – Fusesaver™ OC (Modes)		3	A	X	1	3	5	0	8	C													
RCU Operator Panel – Fusesaver™ OCO (Modes)		3	A	X	1	3	5	0	8	D													

Fusesaver Dimensions

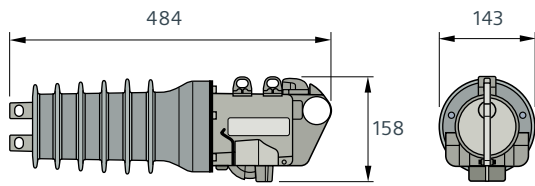

Fusesaver™

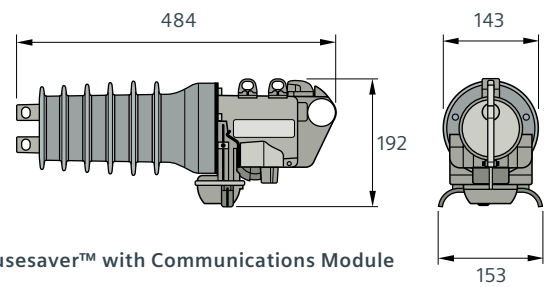

Fusesaver™ with Communications Module

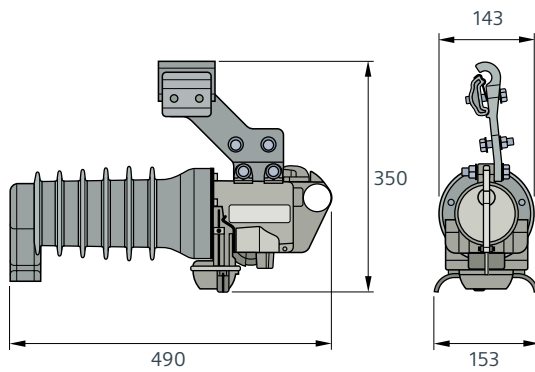

Fusesaver™, Communications Module and line-clamp assembly

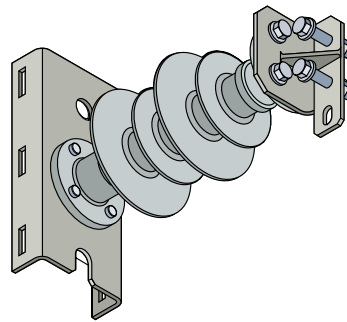
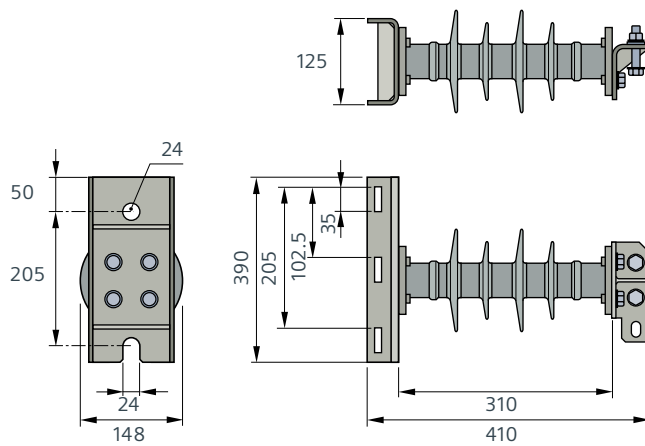

15.5 – 27 kV Fusesaver™ pole-mounting assembly – composite insulator

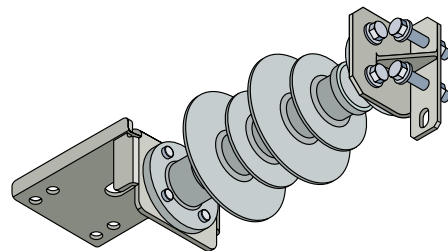
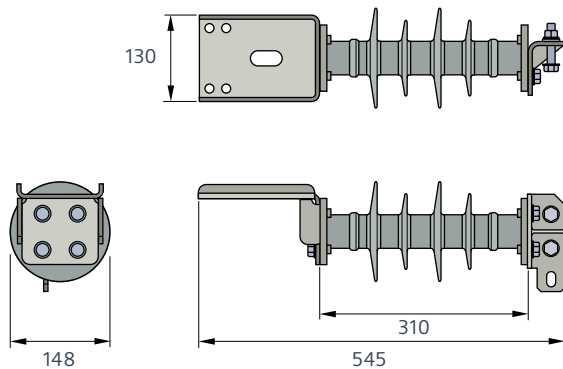

15.5 – 27 kV Fusesaver™ crossarm-mounting assembly – composite insulator

Remote Control Unit Dimensions

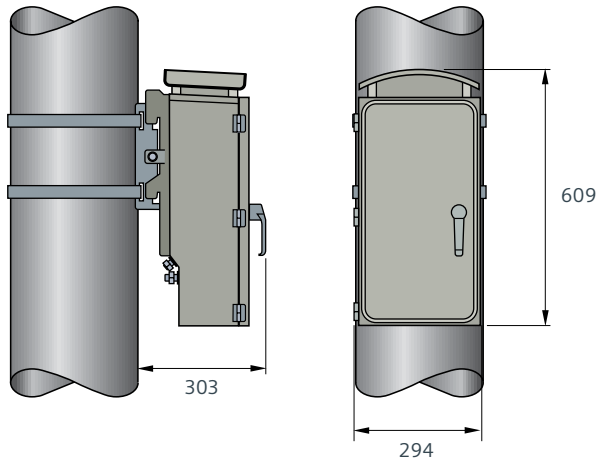

Remote Control Unit (RCU)

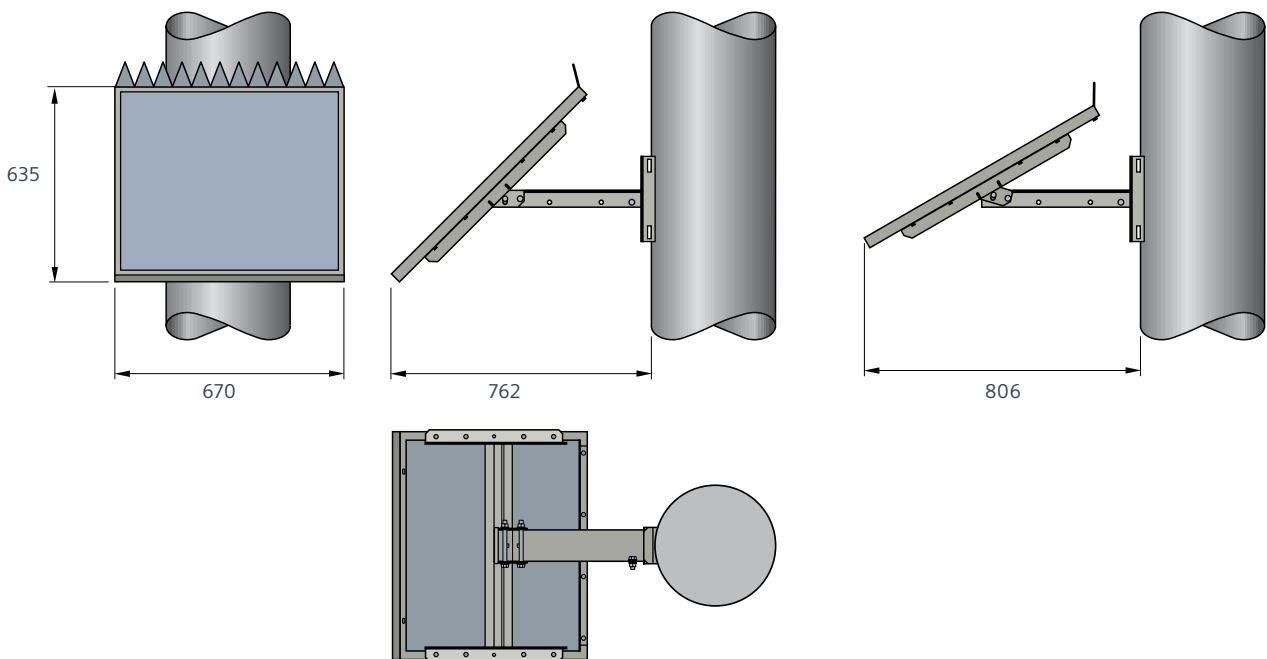

Solar panel (RCU powering option)

Published by and copyright ©

Siemens Ltd.
www.siemens.com.au
Australia Nationwide
Telephone +61 3 9721 2000
Facsimile +61 3 9721 2001

Head Office Australia

885 Mountain Highway
Bayswater VIC 3153
ABN: 98 004 347 880

Manufacturing Facility

Siemens Ltd.
2-4 Union Circuit
Yatala QLD 4207
Email: fusesaver.au@siemens.com

All rights reserved.

Trademarks mentioned in this document are the property of Siemens AG, its affiliates, or their respective owners.

Subject to changes and errors. The information given in this document only contains general descriptions and/or performance features which may not always specifically reflect those described, or which may undergo modification in the course of further development of the products. The requested performance features are binding only when they are expressly agreed upon in the concluded contract.

SIDS-C90001-00-7600